



carbatec®

**SS-400H  
CARBATEC VARIABLE SPEED SCROLL SAW  
WITH ROTARY TOOL**

INSTRUCTIONS MANUAL

[carbatec.com.au](http://carbatec.com.au)

**1** YEAR  
WARRANTY

# THANK YOU FOR CHOOSING carbatec®

Carbatec has been a trusted brand for woodworking enthusiasts and professionals across Australia and New Zealand, since 1987.



Our quality woodworking products are designed and built to offer value and performance, making the latest features and technological advancements more accessible to Aussie woodworkers.

Backed by our no-fuss after-sales care and warranty support, you can trust Carbatec to keep you woodworking, as promised.

**We look forward to sharing in your woodworking journey!**

If you have any questions about our products or service, please call us on **1800 658 111** or email us at [info@carbatec.com.au](mailto:info@carbatec.com.au)

#### Find us on social media

-  [facebook.com/Carbatec](https://facebook.com/Carbatec)
-  [instagram.com/Carbatec](https://instagram.com/Carbatec)
-  [youtube.com/@CarbaTecTheHomeOfWoodworking](https://youtube.com/@CarbaTecTheHomeOfWoodworking)

## WHAT'S IN THE BOX

This Scroll Saw will require a minimal amount of assembly.

1. Remove parts from all of the cartons and lay them on a clean work surface.
2. Remove any protective materials and coatings from all of the parts and the Scroll Saw. The protective coatings can be removed by spraying WD-40 on them and wiping it off with a soft cloth. This may need to be redone several times before all of the protective coatings are removed completely.

### ! CAUTION

**CAUTION: DO NOT** use acetone, gasoline or lacquer thinner to remove any protective coatings.

3. Compare the items below to verify that all items are accounted for before discarding the shipping box.

### ! WARNING

If any parts are missing, do not attempt to plug in the power cord and turn **"ON"** the Scroll Saw. The Scroll Saw can only be turned **"ON"** after all the parts have been obtained and installed correctly.

The following items are provided in the shipping box:



- |                                |                                     |
|--------------------------------|-------------------------------------|
| A. Scroll Saw with foot switch | F. Pinless blade chucks x2          |
| B. Rotary tool attachment      | G. Plastic blade guard              |
| C. Rotary tool accessories     | H. Attachable battery powered light |
| D. Dust collection adaptor     | I. Tool spanner                     |
| E. Allen keys x3               | J. Rubber feet x3 (not shown)       |

Key information can be found on the inspection panel, found on the rear of the machine.

**carbatec**  
QUALITY INSPECTED

Model:
Voltage
Freq:
Phase:
Amp:
kW:
Speed:
Lot No.:
Serial No.:
Date:

Made in **for:**  
**CARBATEC PTY LTD**  
Brisbane - Australia



Record the serial number and date of purchase in your manual for future reference.

SERIAL NUMBER: \_\_\_\_\_

DATE OF PURCHASE: \_\_\_\_\_

---

# CONTENTS

---

Introduction	2
What's in the box	3
Key information	4
Safety instructions - General	6-9
Safety instructions - Scroll Saw	10-11
Safety instructions - Electrical	12
Overview	14
Specifications	15
Assembly	17-18
Changing the saw blades	19-20
Operation	22-25
Maintenance	26
Parts diagram	28
Parts list	29-30
Wiring diagram	31
Warranty details	32
Troubleshooting	33
Blade selection	34-35

---

# SAFETY INSTRUCTIONS

**IMPORTANT!** Safety is the single most important consideration in the operation of this equipment. The following instructions must be followed at all times. Failure to follow all instructions listed below may result in electric shock, fire, and/or serious personal injury. There are certain applications for which this tool was designed. We strongly recommend that this tool not be modified and/or used for any other application other than that for which it was designed. If you have any questions about its application, do not use the tool until you have contacted us and we have advised you.

The purpose of safety symbols is to attract your attention to possible dangers. The safety symbols and the explanations with them deserve your careful attention and understanding. The symbol warnings do not, by themselves, eliminate any danger. The instructions and warnings they give are no substitutes for proper accident prevention measures.

## WARNING

Be sure to read and understand all safety instructions in this manual, including all safety alert symbols such as "**DANGER**," "**WARNING**," and "**CAUTION**" before using this tool. Failure to following all instructions listed below may result in electric shock, fire, and/or serious personal injury.

## SYMBOL MEANING



A safety alert symbol Indicates **DANGER**, **WARNING**, or **CAUTION**. May be used in conjunction with other symbols or pictographs.



**DANGER**

Indicates an imminently hazardous situation, which, if not avoided, will result in death or serious injury.



**WARNING**

Indicates a potentially hazardous situation, which, if not avoided, could result in death or serious injury.



**CAUTION**

Indicates a potentially hazardous situation, which, if not avoided, could result in minor or moderate injury.



**NOTICE**

(Without Safety Alert Symbol) Indicates a situation that may result in property damage.



Carbatec products bearing the Regulatory Compliance Mark (RCM) have been tested in accordance with applicable Australian/New Zealand Standards to ensure their compliance with all mandatory standards and regulations (applicable at time of original sale). Carbatec Pty Ltd are registered as a responsible supplier with relevant Australian government departments and our products are registered on the EESS & ACMA database.



# GENERAL SAFETY

Operating a power tool can be dangerous if safety and common sense are ignored. The operator must be familiar with the operation of this machine. Read this manual to understand this machine. **DO NOT OPERATE** this machine **IF YOU DO NOT FULLY UNDERSTAND** the limitations of this tool. **DO NOT MODIFY** this machine in any way.



## WARNING

### BEFORE USING THIS MACHINE

To avoid serious injury and damage to the tool, read and follow all of the Safety and Operating Instructions before operating the machine.

- SOME DUST CREATED BY USING POWER TOOLS CONTAINS CHEMICALS** known to cause cancer, birth defects, or other reproductive harm.

Some examples of these chemicals are:

- Lead from lead-based paints.
- Crystalline silica from bricks, cement, and other masonry products.
- Arsenic and chromium from chemically treated lumber.

Your risk from these exposures varies, depending on how often you do this type of work. To reduce your exposure to these chemicals: work in a well ventilated area and work with approved safety equipment, such as those dust masks that are specially designed to filter out microscopic particles.

- 2. READ** this entire manual. **LEARN** how to use the tool for its intended applications.
- 3. GROUND ALL TOOLS.** If the tool is supplied with a 3-prong plug, it must be plugged into a 3-contact electrical receptacle. The third prong is used to ground the tool and provide protection against accidental electric shock.
- 4. AVOID A DANGEROUS WORKING ENVIRONMENT.** Do not use electrical tools in a damp environment or expose them to rain.
- 5. DO NOT USE** electrical tools in the presence of **FLAMMABLE** liquids or gases.
- 6. ALWAYS KEEP THE AREA CLEAN,** well lit, and organized. Do not work in an environment with floor surfaces that are slippery from debris, grease, and wax.
- 7. KEEP VISITORS AND CHILDREN AWAY.** Do not permit people to be in the immediate work area, especially when the electrical tool is operating.
- 8. DO NOT FORCE THE TOOL** to perform an operation for which it was not designed. It will do a safer and higher quality job by only performing operations for which the tool was intended.

## GENERAL SAFETY

- 9. WEAR PROPER CLOTHING.**  
Do not wear loose clothing, gloves, neckties, or jewellery. These items can get caught in the machine during operations and pull the operator into the moving parts. The user must wear a protective cover on their hair, if hair is long, to prevent it from contacting any moving parts.
- 10. CHILDPROOF THE WORKSHOP AREA** by removing switch keys, unplugging tools from the electrical receptacles, and using padlocks.
- 11. ALWAYS UNPLUG THE TOOL FROM THE ELECTRICAL RECEPTACLE** when making adjustments, changing parts or performing any maintenance.
- 12. KEEP PROTECTIVE GUARDS IN PLACE AND IN WORKING ORDER.**
- 13. AVOID ACCIDENTAL STARTING.** Make sure that the power switch is in the "OFF" position before plugging in the power cord to the electrical receptacle.
- 14. REMOVE ALL MAINTENANCE TOOLS** from the immediate area prior to turning "ON" the machine.
- 15. USE ONLY RECOMMENDED ACCESSORIES.** Use of incorrect or improper accessories could cause serious injury to the operator and cause damage to the tool. If in doubt, check the instruction manual that comes with that particular accessory.
- 16. NEVER LEAVE A RUNNING TOOL UNATTENDED.** Turn the power switch to the "OFF" position. Do not leave the tool until it has come to a complete stop.
- 17. DO NOT STAND ON A TOOL.** Serious injury could result if the tool tips over, or you accidentally contact the tool.
- 18. DO NOT STORE ANYTHING ABOVE OR NEAR THE TOOL** where anyone might try to stand on the tool to reach it.
- 19. MAINTAIN YOUR BALANCE.** Do not extend yourself over the tool. Wear oil resistant rubber soled shoes. Keep floor clear of debris, grease, and wax.
- 20. MAINTAIN TOOLS WITH CARE.** Always keep tools clean and in good working order. Keep all blades and tool bits sharp, dress grinding wheels and change other abrasive accessories when worn.
- 21. EACH AND EVERY TIME, CHECK FOR DAMAGED PARTS PRIOR TO USING THE TOOL.** Carefully check all guards to see that they operate properly, are not damaged, and perform their intended functions. Check for alignment, binding or breaking of moving parts. A guard or other part that is damaged should be immediately repaired or replaced.
- 22. DO NOT OPERATE TOOL WHILE TIRED, OR UNDER THE INFLUENCE OF DRUGS, MEDICATION OR ALCOHOL.**



- 23. SECURE ALL WORK.** Use clamps or jigs to secure the work piece. This is safer than attempting to hold the work piece with your hands.
- 24. STAY ALERT, WATCH WHAT YOU ARE DOING, AND USE COMMON SENSE WHEN OPERATING A POWER TOOL.** A moment of inattention while operating power tools may result in serious personal injury.
- 25. ALWAYS WEAR A DUST MASK TO PREVENT INHALING DANGEROUS DUST OR AIRBORNE PARTICLES,** including wood dust, crystalline silica dust and asbestos dust. Direct particles away from face and body. Always operate tool in well ventilated area and provide for proper dust removal. Use dust collection system wherever possible. Exposure to dust may cause serious and permanent respiratory or other injury, including silicosis (a serious lung disease), cancer, and death. Avoid breathing dust, and avoid prolonged contact with dust. Allowing dust to get into your mouth or eyes, or lay on your skin may promote absorption of harmful material. Always use properly fitting AS/NZS approved respiratory protection appropriate for the dust exposure, and wash exposed areas with soap and water.
- 26. USE A PROPER EXTENSION CORD IN GOOD CONDITION.** Use of extension cords should be avoided where possible. When using an extension cord, be sure to have a cord heavy enough to carry the current your product will draw, and with compatible pin configuration and connections (NEVER use an extension cord rated at less than your machine). Longer run extensions will need heavier duty extension cords. Only connect your extension cord or machine to a receptacle that accepts your plug and never modify your plug to suit a receptacle.

# SPECIFIC SCROLL SAW SAFETY

**NOTE:** According to the applicable product liability law, the manufacturer of this device is not liable for damages which arise on or in connection with this device in case of:

- Improper handling
- Non-compliance with the instructions for use
- Repairs by third party, non authorised skilled workers
- Installation and replacement of non-genuine spare parts
- Improper use

## RECOMMENDATIONS:

- Read the entire text of the operating instructions prior to the assembly and operation of the device. These operating instructions are intended to make it easier for you to get familiar with your device and utilise its intended possibilities of use.
- The operating instructions contain important notes on how to work safely with your machine and how to avoid dangers, and increase the reliability and working life of the machine.
- Retain and store these instructions near the machine. The instructions must be read and carefully observed by each operator prior to starting the work.
- In addition to the safety notes contained in the present operating instructions and the special regulations of your country, the generally recognised technical rules for the operation of wood working machines must be observed.



**The device and packaging materials are not toys! Children must not be allowed to play with plastic bags, film and small parts! There is a risk of swallowing and suffocation!**

## INTENDED USE

- The machine must only be used in technically perfect condition in accordance with its designated use and the instructions set out in the operating manual, and only by safety-conscious persons who are fully aware of the risks involved in operating the machine. Any functional disorders, especially those affecting the safety of the machine, should therefore be rectified immediately. The safety, work and maintenance instructions of the manufacturer as well as the technical data given in the calibrations and dimensions must be adhered to.
- Relevant accident prevention regulations and other, generally recognised safety-technical rules must also be adhered to.
- The machine may only be used, maintained, and operated by persons familiar with it and instructed in its operation and procedures. Arbitrary alterations to the machine release the manufacturer from all responsibility for any resulting damages.
- The machine may only be used with original accessories and tools made by or recommended by the manufacturer.
- Any other use exceeds authorisation. The manufacturer is not responsible for any damages resulting from unauthorized use; risk is the sole responsibility of the operator.

Please note that our equipment has not been designed for use in commercial, trade or industrial applications. Our warranty may be voided if the equipment is used in commercial, trade or industrial businesses or for equivalent purposes.

## SAFETY FOR SCROLL SAWS

- This scroll saw is intended for use in dry conditions, and for indoor use only.
- Do not cut pieces of material too small to hold by hand outside the blade guard.
- Avoid awkward hand positions where a sudden slip could cause a hand to move into the blade.
- Always use the blade guard to avoid possible injury due to blade breakage.
- Never leave the work area with the power connected, or before the machine has come to a complete stop.
- Do not perform layout, assembly or set up work on the table while the cutting tool is in operation.
- Never turn your scroll saw on before clearing the table of all objects: (tools, scraps of wood, etc) except for the workpiece and related feed or support devices for the operation planned.

## REMAINING HAZARDS

The machine has been built using modern technology in accordance with recognised safety rules. Some remaining hazards, however, may still exist.

- Long hair and loose clothing can be hazardous when the work piece is rotating. Wear personal protective gear such as a hair net and tight fitting work clothes.
- Saw dust and wood chips can be hazardous. Always wear AS/NZS approved personal protective gear such as safety goggles, dust mask and hearing protection.
- The use of incorrect or damaged mains cables can lead to injuries caused by electricity.
- Even when all safety measures are taken, some remaining hazards which are not yet evident may still be present.
- Remaining hazards can be minimised by following the instructions in Safety Precautions, Proper Use and in the entire operating manual.
- Do not force the machine unnecessarily: excessive cutting pressure may lead to rapid deterioration of the blade and a decrease in performance in terms of finish and cutting precision.
- Avoid accidental starts: do not press the start button while inserting the plug into the socket.

# ELECTRICAL SAFETY



## WARNING

**This tool must be grounded while in use to protect the operator from electric shock.**

**IN THE EVENT OF A MALFUNCTION OR BREAKDOWN**, grounding provides the path of least resistance for electric current and reduces the risk of electric shock. This tool may be equipped with an electric cord that has an equipment grounding conductor and a grounding plug. **The plug MUST Be plugged** into a matching electrical receptacle that is properly installed and grounded in accordance with **ALL** local codes and ordinances.

### DO NOT MODIFY THE PLUG PROVIDED.

If it will not fit the electrical receptacle, have the proper electrical receptacle installed by a qualified electrician.

**IMPROPER ELECTRICAL CONNECTION** of the equipment grounding conductor can result in risk of electric shock. The conductor with the green insulation (with or without yellow stripes) is the equipment grounding conductor. **DO NOT** connect the equipment grounding conductor to a live terminal if repair or replacement of the electric cord or plug is necessary.

### CHECK WITH A QUALIFIED ELECTRICIAN

or service personnel if you do not completely understand the grounding instructions, or if you are not sure the tool is properly grounded.

**Use only a 3-wire extension cord that has a 3-prong grounding plug and a 3-pole receptacle that accepts the tool's plug. Replace a damaged or worn cord immediately.**

Power tools and machinery are intended for use on a circuit that has an electrical receptacle as shown in **FIGURE A** that shows a 10 Amp 3-wire electrical plug and corresponding electrical receptacle that has a grounding conductor.

If this particular tool has been designed and fitted with a two prong electrical plug, ensure it displays the 'Double Insulated' logo shown in **FIGURE B**, before connecting to a 3-wire receptacle.



## WARNING

**Never modify the standard fitted electrical plugs to fit your receptacle.**





SS-400H

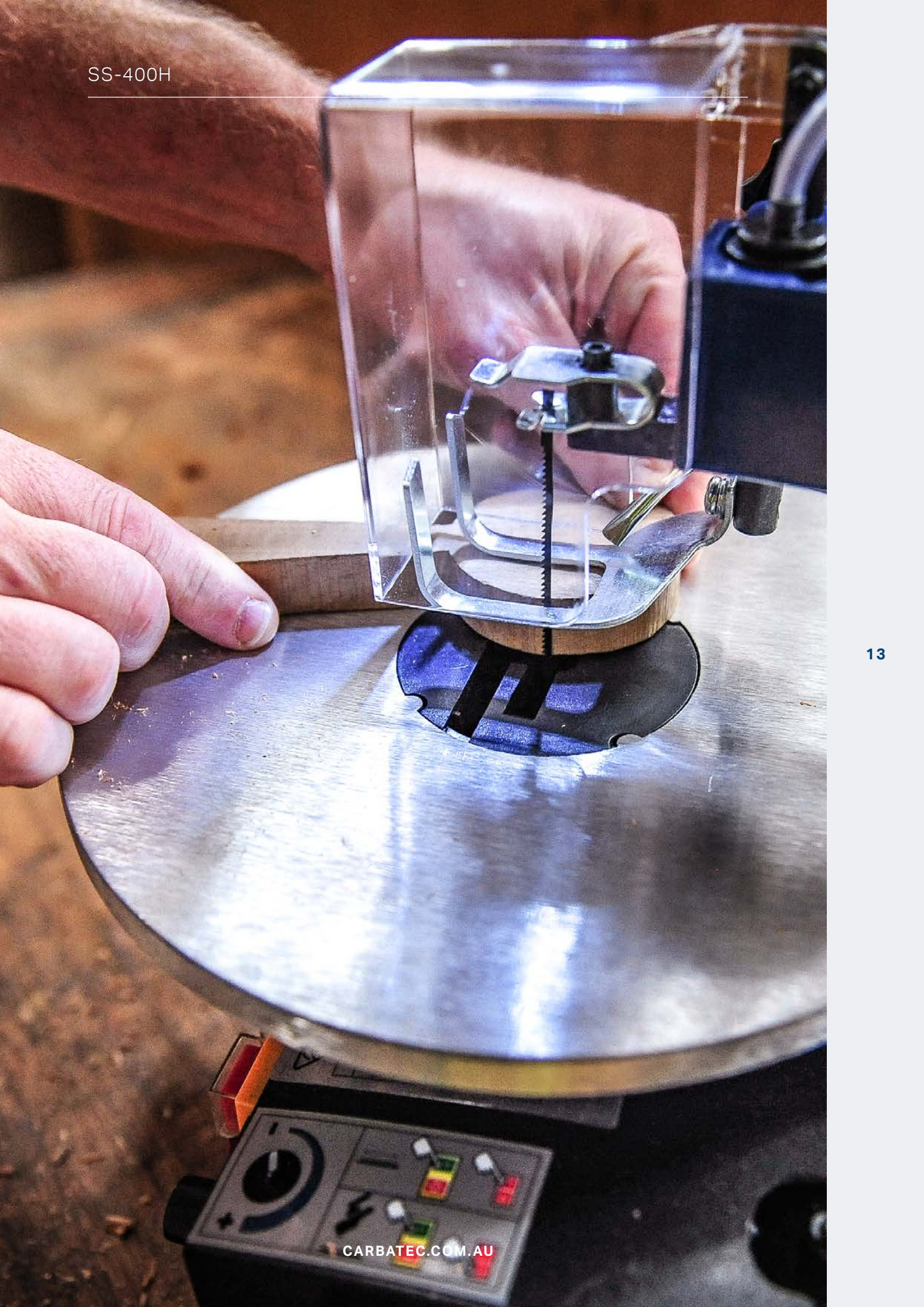



## OVERVIEW



## VARIABLE SPEED SCROLL SAW OVERVIEW

Fig. 1

- |                                   |   |
|-----------------------------------|---|
| A. Blade tension lever and screw. | G. Angle scale                          |
| B. Blade guard                    | H. Battery powered light                |
| C. Work piece hold down           | I. Rotary tool with flexible shaft      |
| D. Air blower                     | J. Setting gauge for pinless saw blades |
| E. Speed control dial             | K. Foot switch                          |
| F. On/Off button                  | L. Continuous / foot switch control     |



# SPECIFICATIONS

<b>WARRANTY</b>	1 year
<b>MOTOR</b>	125 W (1/6 HP) Induction - Regular 10 Amp plug
<b>BLADE LENGTH</b>	127 mm
<b>CUTS PER MINUTE</b>	550 to 1600
<b>DUST PORT</b>	40 mm
<b>MAXIMUM DEPTH OF CUT</b>	50 mm
<b>STROKE</b>	15 mm
<b>TABLE MATERIAL</b>	Aluminium Casting
<b>TABLE TILT</b>	0° - 45°
<b>WORKSHOP FOOTPRINT (WxDxH)</b>	640 x 300 x 370 mm
<b>WORK LIGHT PROVISION</b>	Included (LED - Battery operated)
<b>WEIGHT (GROSS/NET)</b>	14 kg / 11 kg
<b>PACKING SIZE</b>	700 x 310 x 380 mm

**NOTE:** The specifications, photographs, drawings and information in this manual represent the current machine model when the manual was prepared. Changes and improvements may be made at any time, with no obligation on the part of Carbatec to modify previously delivered units. Reasonable care has been taken to ensure that the information in this manual is correct, to provide you with the guidelines for the proper safety, assembly and operation of this machine.







# ASSEMBLY INSTRUCTIONS

## BLADE GUARD ASSEMBLY.

**Fig. 2**

1. Install the blade guard to the holder as shown in the diagram. Secure the screws with a nut and washer.
2. Lift the saw onto the frame and base and push it onto the workbench.
3. Familiarize yourself with the saw operating elements and features.



## MOUNTING THE SAW ON A WORK BENCH.

**Fig. 3**

A workbench made from solid wood is better than one made of plywood, as interfering vibrations and noise are more noticeable with plywood.

The necessary tools and small parts for assembling the saw on a workbench are not supplied with the saw. However, use equipment of at least the following size:

### Mounting Hardware (not included):

- 4 Hexagonal bolts (6mm) 1/4-20 x length
- 4 Flat seal (7mm) 9/321.0
- 4 Washers (7mm) 9/321.0.
- 8 Hexagonal nuts (6 mm) 1/4-20

Drill holes into the seating surface and then insert the screws.

**NOTE:** A rubber base for reduction of noise is not supplied with the saw either. However, we recommend that you use such a base to keep vibration and noise to a minimum.

Ideal size 400 x 240 mm.

**Fig. 3**

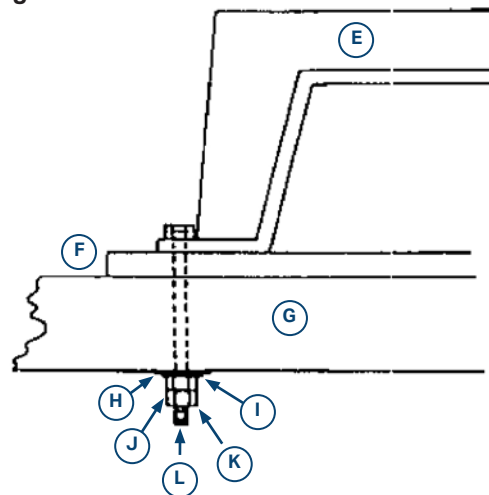

- E. Saw body
- F. Rubber base
- G. Work bench
- H. Flat seal
- I. Washer
- J. Hexagonal nut
- K. Lock nut
- L. Hexagonal bolt

# SETTING THE TABLE

## SETTING THE TABLE FOR 90° CUTS

**Fig. 4**

### Setting the angle scale:

1. Release the star knob (A) and bring the saw bench (B) to a correct angle (D) in relation to the saw blade (C).
2. Use a square to measure the angle between the blade and the bench.
3. Tighten the star knob (A) again when 90°.

**NOTE:** The angle scale is a useful piece of supplementary equipment, but should not be used for precision work. Use scrap wood for saw tests, adjust the bench if necessary.

**NOTE:** The bench should not rest on the motor block, this can cause undesirable noise and vibration.

## SETTING THE TABLE FOR ANGLED CUTS.

**Fig. 4 and 5**

1. The saw bench can be positioned at up to a 45° angle position to the left of the horizontal position.
2. You can read off the approximate angle by using the angle scale located under the work bench. For more exact adjustment, use scrap wood for some saw tests; adjust the bench if necessary.
3. Follow the instructions above before tensioning the star knob.

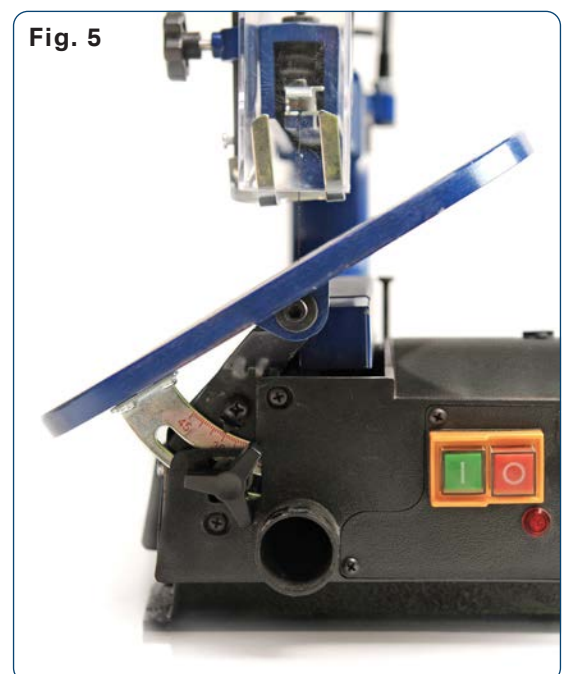
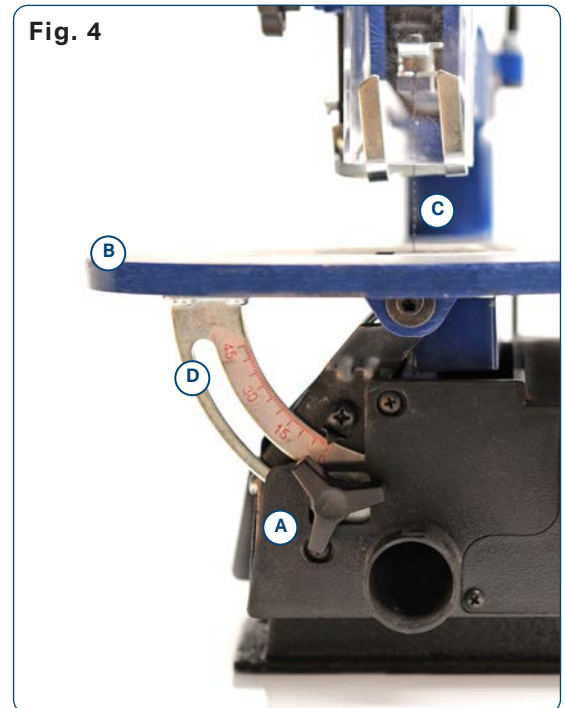

# CHANGING THE SAW BLADES

**Switch off the saw and remove the mains supply plug before installing saw blades in order to avoid injuries caused by unintentional activation of the saw.**

## A. PINLESS BLADES

### Fig. 6

Use the blade chucks (E) with pinless saw-blades. The saw-blade is fixed with Allen screws.

### A1 SAW-BLADE REMOVAL

#### Fig. 7, 8 and 10

1. Extract the saw-blade by sliding the table's insert up, then lift up the blade tension lever (I).
2. Slightly press the upper arm (M) down (**fig. 10**).
3. Then remove the saw blade by pulling it forward out of the supports and through the access in the table.

### A2 INSERTING THE SAW-BLADE:

1. Preset the pinless blade into the blade chucks, using the blade setting jig built into the top arm (**fig. 6**).
2. Put the saw-blade with the two adapters into the lower support, the other end into the upper support.
3. Slightly press the upper arm (M) down (**fig 10**) before hooking it in.
4. Tighten the blade with the tightening screw (I) (**fig.7**) by lowering the tensioning lever. Rotate the lever clockwise to further tension the blade.

**NOTE:** Blade teeth on most scroll saw blades should be facing down towards the table.

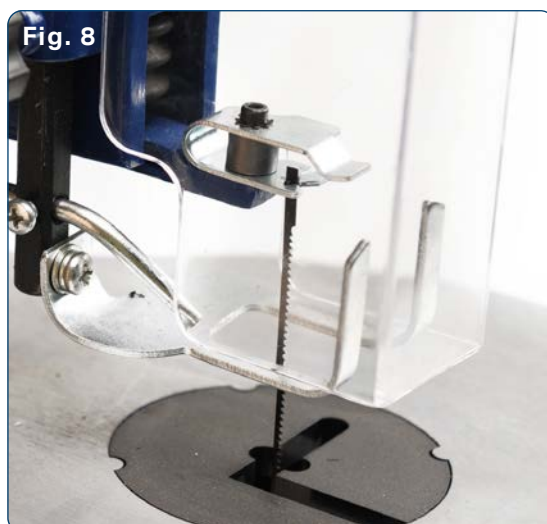

# CHANGING THE SAW BLADES

## B. PINNED SAW BLADE

### Fig. 7 to 11

Pinless blade chucks are not required for pinned blades. Store your pinless blade chucks in a safe place for re-use.

### B1 SAW BLADE REMOVAL

#### Fig. 7 and 8

1. Extract the saw-blade by sliding the table's insert up, then lift up the blade tension lever (I).
2. Slightly press the upper arm (M) down (fig. 10).
3. Then remove the saw blade by pulling it forward out of the supports and through the access in the table.

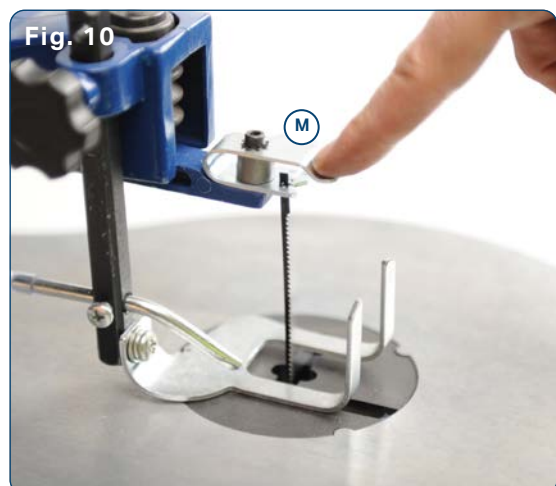
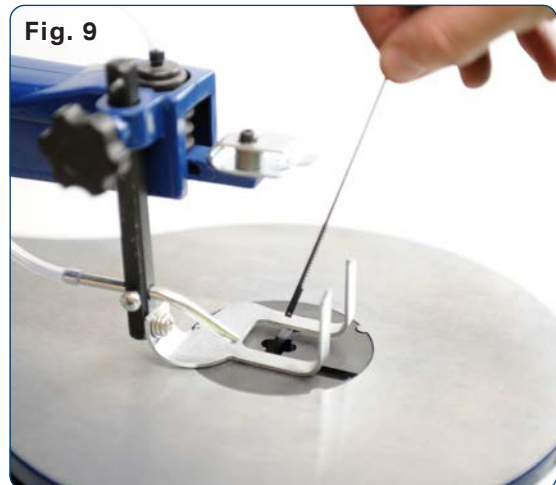

### B2 INSERTING THE SAW-BLADE

#### Fig. 7, 9, 10 and 11

1. Put the saw-blade into the lower support, the other end into the upper support.
2. Slightly press the upper arm (M) down (fig 10) before hooking it in.
3. Tighten the blade with the tightening screw (I) (fig.7) By lowering the tensioning lever. Rotate the lever clockwise to further tension the blade.



**Note:** Blade teeth on most scroll saw blades should be facing down towards the table.



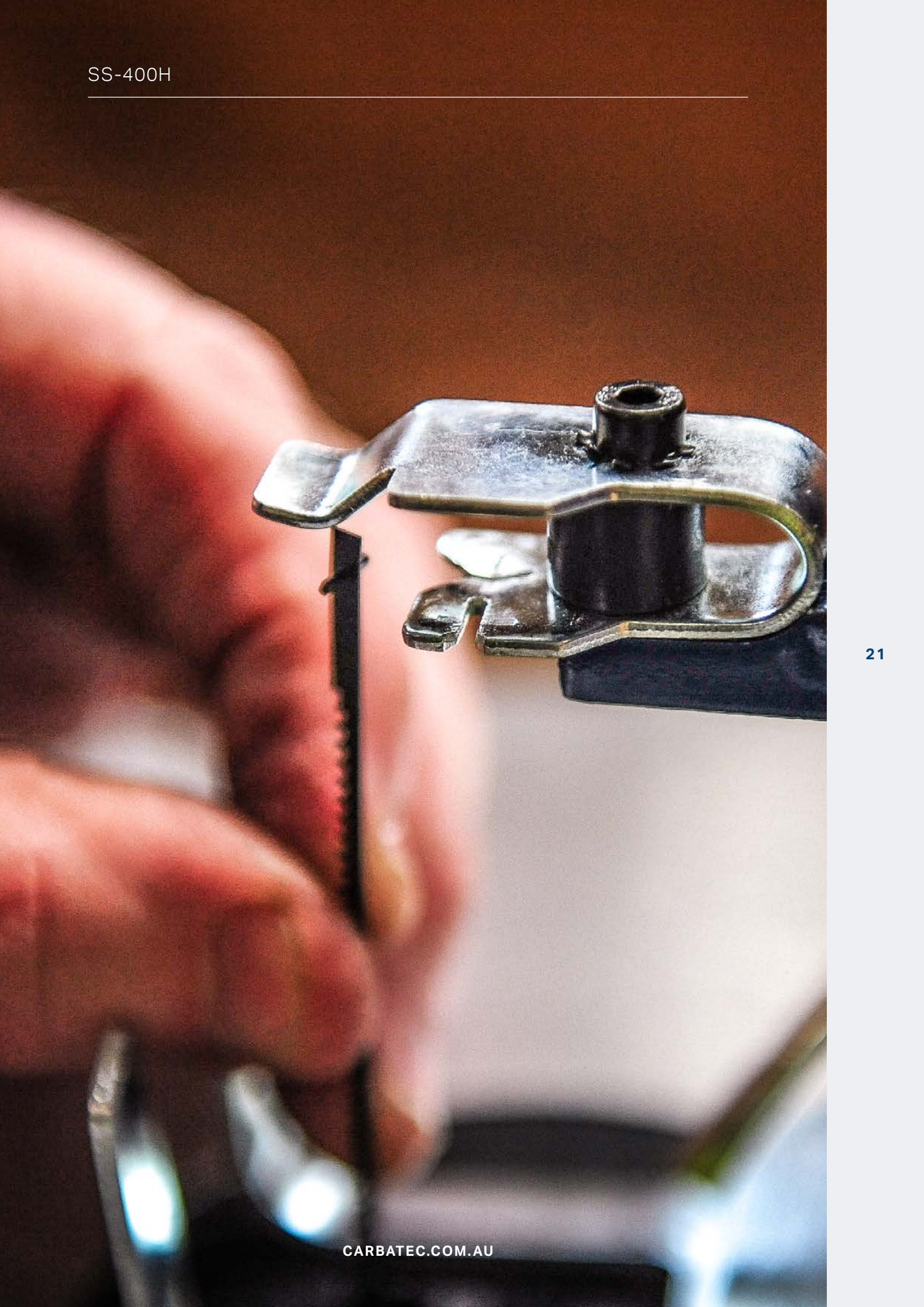

# OPERATION

A scroll saw is fundamentally a curve cutting tool but which can also carry out straight and angled edge cuts. Familiarise yourself with the following important points prior to commissioning the saw.

- The saw does not automatically cut wood. You must feed the wood against the saw blade manually.
- Feed the wood slowly against the saw blade as the saw blade teeth are small and cut only while moving.
- All persons carrying out work with the saw require training. The saw blade may break easily during this training time while the operator is still unfamiliar with the saw.
- The saw is best suited for sheets of wood less than 2.5 cm thick.
- Feed the wood slowly against the blade and avoid abrupt curves to prevent the saw blade from breaking, if you wish to cut wood sheets thicker than 2.5 cm.
- Saw blade teeth blunt over time, saw blades must be replaced when they become blunt.
- Try and make sure that the saw blade follows the grain of the wood in order to obtain a clean cut.
- The saw speed must be reduced to minimum when cutting precious and non-ferrous metals. Appropriate specialty blades MUST be used.



**Switch off the saw and remove the mains supply plug before installing saw blades in order to avoid injuries caused by unintentional activation of the saw.**

## INSIDE CUTS

This saw is suited also to inside cuts, cuts not starting at the edge of the work piece. Proceed as follows:

- Drill a 6mm hole in the work piece.
- Loosen the blade tensioner and release the tension in the blade.
- Place the bore hole over the saw blade slot in the work bench.
- Install the saw blade through the hole in the work piece and through the work blade slot, and fasten the blade to the holders and re tension.
- When you have completed the inside cut, remove the saw blade and then remove the workpiece from the bench.



**FLEXIBLE SHAFT**

**Fig. 12-14**

1. Remove protective cap (O) from the threaded attachment (**Fig. 13**).
2. Thread flexible shaft onto the threaded attachment (**Fig. 14**).
3. Clamp tool in the drill chuck with supplied spanner (Max 3.2mm shank).
4. Firmly hold rotary tool shaft by the handle only.

**! CAUTION**

**DO NOT attempt to touch or hold rotating tools or bits and ensure blade guard is lowered to completely cover blade.**

Having finished the work, remove the flexible shaft and place the protective cap in place.

**! CAUTION**

**The machine may start due to unintentional actuation of the foot switch in the foot switch mode.**

**SWITCHING ON/OFF**

**Fig. 15**

It is possible to switch the saw on by pressing the green "I" button (P).

In order to switch the saw off again, it is necessary to press the red "O" button (Q).

The red warning light (R) indicates whether the machine is switched on or off. The machine is switched on when this lights up. (The machine only starts up in the foot switch mode once the pedal is actuated, the red warning light illuminates anyway.)

**Fig. 12**



**Fig. 13**



**Fig. 14**

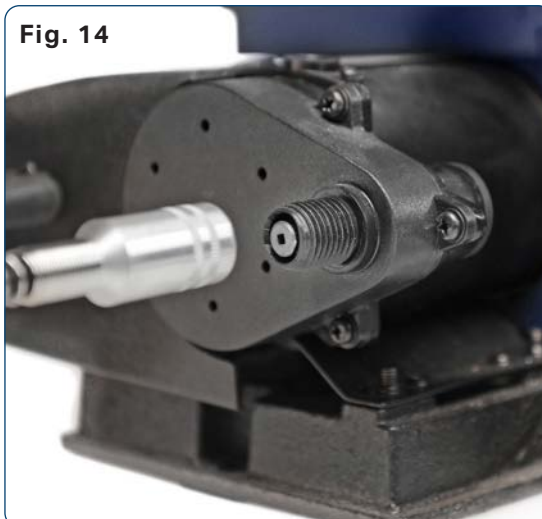

## OPERATION

You can only switch between foot switch and continuous operation when the red warning light is not illuminated. If necessary, switch machine off first by pressing the red button "O" (Q).

Make sure you are aware of what operating mode (pedal/continuous operation) your machine is in before switching it on.

Beware of unintentional actuation of the foot switch. Set the pedal (S) on the ground. The machine can be switched on/off in pedal mode when the pedal is actuated.

A foot switch for switching on/off is practical, especially for internal cuttings, since your hands are kept free and you can fully concentrate on the work piece under the scroll saw. However, it cannot influence the speed.

With the continuously variable electronic speed control (5), the cutting speed can be increased by turning to the right or reduced by turning to the left.

### FOOT SWITCH / CONTINUOUS OPERATION

#### Fig. 15 and 16

The machine can be operated in continuous operation or with the additional foot switch (S). The switch (T) is used to select between the operating modes. The operating mode should always be selected when the machine is switched off.

The machine is in the foot switch mode when the switch (T) is at the "0" position. Press the foot switch down to start the machine or rotary tool.

The machine is in the continuous mode when the switch (T) is at the "I" position. Use the front mounted (P), (Q) to start or stop the machine.

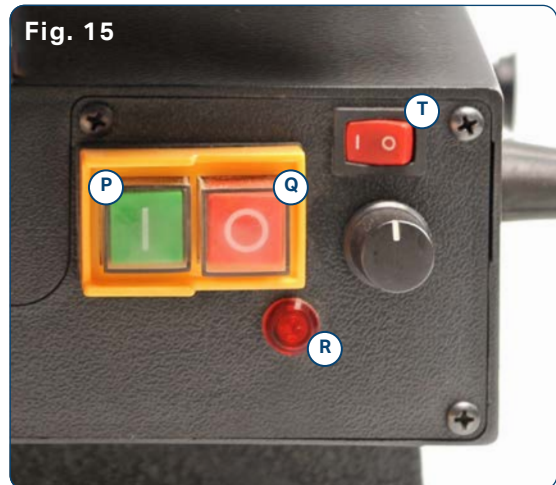

## LIGHTING SYSTEM

### Fig. 17

The lighting system can be switched on by pressing the switch (b) on the back of the lamp.

The lighting system is switched off if the switch is pressed again.

## TO CHANGE THE BATTERIES (2X AAA)

1. Open the battery compartment on the bottom of the light by removing the three screws (c) using a Phillips screwdriver.
2. Insert the new batteries. Dispose of the old batteries properly.
3. Fit the cover of the battery compartment in reverse order.



# MAINTENANCE



## WARNING

In the interest of operational safety, always switch off the saw and remove the mains plug before carrying out maintenance work.

## GENERAL

Wipe chips and dust off the machine from time to time using a cloth.

The application of a wax coating or surface protectant on the workbench makes feeding the workpiece to the blade easier.

## MOTOR

The mains cable should be replaced by a licensed electrician immediately if pulled out, cut or damaged in any other way.

**Note: Do not lubricate the motor bearings or internal parts!**

## SAW ARM BEARINGS

Lubricate the saw arm bearings every 50 hours. Proceed as follows (Fig. 18).

1. Turn the saw to the side
2. Apply a generous amount of SAE 20 oil to the shaft end and bronze bearings (U).
3. Let the lubricant oil work in overnight.
4. Repeat the procedure the next day on the other side of the saw.

There are no parts inside the equipment which require additional maintenance.



Fig. 18

## ACCESSORIES

### Pinless saw blade mixed pack

3 of each blade type (6 types)

Pack of 18

Product Code: PEG-90-6X3AX

### Pinless saw blade skip tooth mixed pack

3 of each blade type (6 types)

Pack of 18

Product Code: PEG-90-6X3EX

**Note:** See our website for full range of pinned and pinless blades.  
[carbatec.com.au/brands/pegas/scroll-saw-blades](http://carbatec.com.au/brands/pegas/scroll-saw-blades)

## STORAGE

Store the device and its accessories in a dark, dry and frost-proof place that is inaccessible to children. The optimum storage temperature is between 5°C and 30°C.



SS-400H

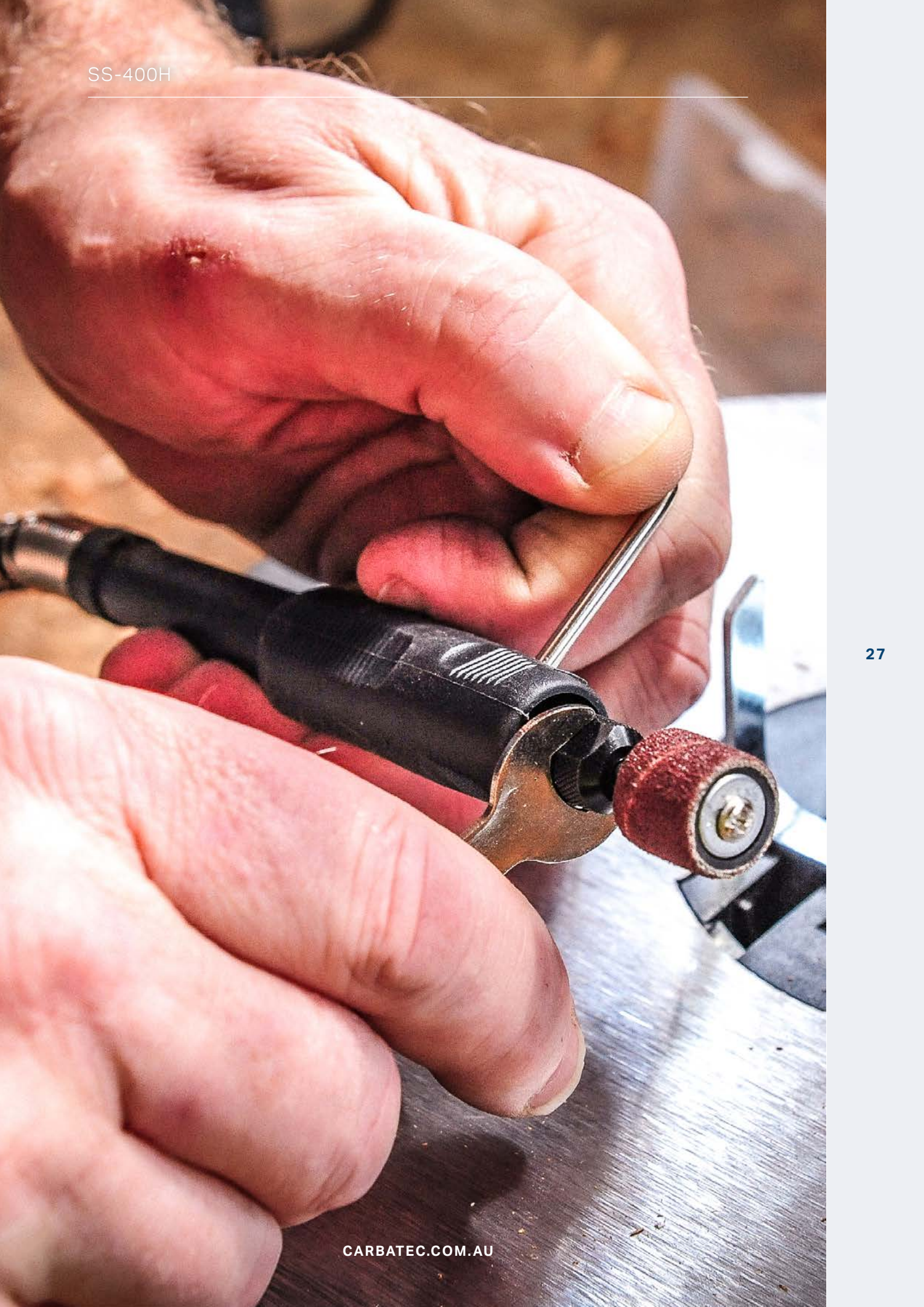



## Variable Speed Scroll Saw SS-400H

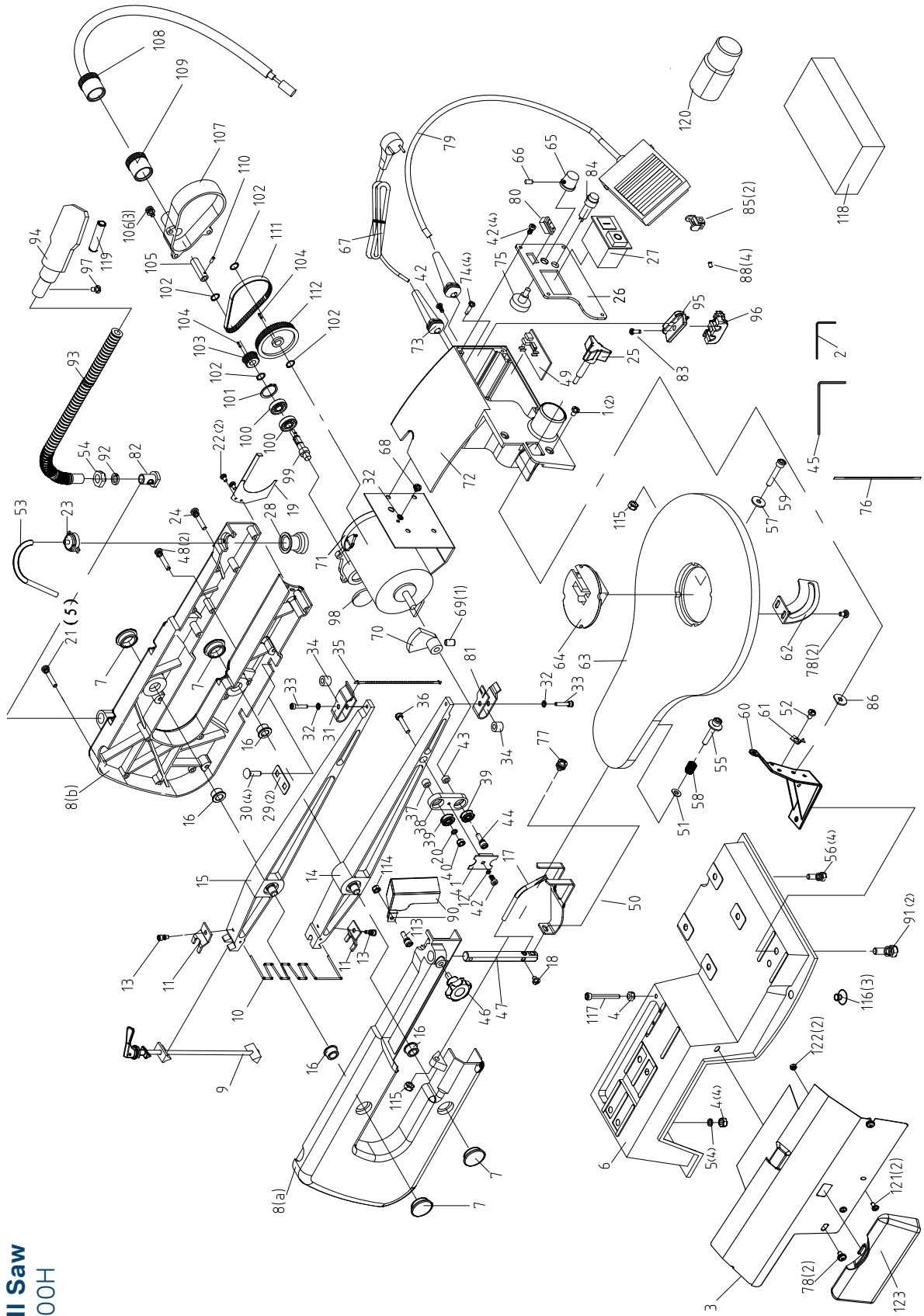

## PARTS LIST

ITEM CODE	DESCRIPTION	ITEM CODE	DESCRIPTION
SS-400H-1	PHILIPS SCREW M5X8	SS-400H-31	BLADE UPPER BRACKET
SS-400H-2	WRENCH S=2.5	SS-400H-32	STAR WASHER D4
SS-400H-3	SIDE COVER	SS-400H-33	HEX SOCKET BOLT M4X20
SS-400H-4	HEX NUT TYPE I M6	SS-400H-34	BRACKET CUSHION
SS-400H-5	SPRING WASHER D6	SS-400H-35	BLADE 15TPI PIN
SS-400H-6	BASE	SS-400H-36	HEX SOCKET COLUMN HEAD BOLT M5X25
SS-400H-7	OIL CAP	SS-400H-37	BIG CUSHION
SS-400H-8AB	RIGHT & LEFT ARM HOUSING	SS-400H-38	ECCENTRICITY CONNECTOR PIECE
SS-400H-9	TENSION POLE ASSY	SS-400H-39	BEARING 625Z
SS-400H-10	EXTENSION SPRING	SS-400H-40	HEX NUT M5
SS-400H-11	PRESSURE PLATE	SS-400H-41	CONNECTOR PIECE CLAMPING BOARD
SS-400H-12	SPRING WASHER D4	SS-400H-42	SELF TAPPING SCREW ST4.2X9.5
SS-400H-13	PHILIPS SCREW & SPRING WASHER ASSY M4X10	SS-400H-43	SMALL CUSHION
SS-400H-14	LOWER ARM	SS-400H-44	HEX SOCKET COLUMN HEAD SCREW & SPRING WASHER ASSY M5X16
SS-400H-15	UPPER ARM	SS-400H-45	WRENCH S3
SS-400H-16	OIL BEARING	SS-400H-46	COMPRESSOR POLE LOCKING HANDLE
SS-400H-17	BLAST PIPE	SS-400H-47	COMPRESSOR POLE
SS-400H-18	PHILIPS SCREW M5X6	SS-400H-48	HEXAGON SOCKET CAP SCREW & SPRING WASHER ASSY M5X30
SS-400H-19	PROTECTION PLATE ASSY	SS-400H-49	PCB WITH EMC FILTER & POTENTIOMETER
SS-400H-20	SPRING WASHER D5	SS-400H-50	BLADE FENDER BRACKET
SS-400H-21	PHILIPS SCREW & SPRING WASHER M5X35	SS-400H-51	FLAT WASHER D6
SS-400H-22	PHILIPS SCREW M4X6	SS-400H-52	PHILIPS SCREW M6X10
SS-400H-23	BELLOWS CAP	SS-400H-53	PVC PIPE
SS-400H-24	PHILIPS SCREW & SPRING WASHER ASSY M5X28	SS-400H-54	HEX NUT M10X1
SS-400H-25	WORK TABLE LOCKING HANDLE	SS-400H-55	HEXAGON SOCKET CAP SCREW & FLAT WASHER ASSY M6X40
SS-400H-26	JUNCTION BOX COVER	SS-400H-56	HEXAGON HEAD BOLT & SPRING WASHER ASSY M6X16
SS-400H-27	SWITCH KJD20-2 SWT-KJD-20-2	SS-400H-57	FLAT WASHER D6
SS-400H-28	BELLOWS	SS-400H-58	COMPRESSION SPRING
SS-400H-29	FIXING PLATE	SS-400H-59	HEXAGON SOCKET CAP SCREWS M6X25
SS-400H-30	STEP BOLT M6X20	SS-400H-60	WORK TABLE BRACKET

## PARTS LIST

ITEM CODE	DESCRIPTION	ITEM CODE	DESCRIPTION
SS-400H-61	POINTER	SS-400H-95	PRESSING PLATE UPPER
SS-400H-62	DIVIDED CIRCLE	SS-400H-96	PRESSING PLATE LOWER
SS-400H-63	WORK TABLE	SS-400H-97	PHILIPS SCREW M4X8
SS-400H-64	WORK TABLE INSERT	SS-400H-98	DUST COVER
SS-400H-65	SPEED ADJUSTING KNOB	SS-400H-SIASY	SPEED INCREASER ASSEMBLY
SS-400H-66	HEXAGON SOCKET SET SCREW M5X6	SS-400H-99	SPEED INCREASER SHAFT
SS-400H-67	POWER CORD WITH PLUG 3X0.75MM2	SS-400H-100	SEALING BEARING 608
SS-400H-68	PHILIPS SCREW & SPRING WASHER & FLAT WASHER ASSY M4X10	SS-400H-101	RETAINER RING D22
SS-400H-69	HEXAGON SOCKET SET SCREW M8X8	SS-400H-102	SPLIT WASHER D6
SS-400H-70	ECCENTRIC WHEEL	SS-400H-103	SMALL BELT WHEEL
SS-400H-71	DC MOTOR Z56	SS-400H-104	KEY 3X3X8
SS-400H-72	SWITCH BOX	SS-400H-105	COUPLER
SS-400H-73	POWER CORD SHEATH	SS-400H-106	PHILIPS SCREW & FLAT WASHER ASSY M5X12
SS-400H-74	PHILIPS SCREW M4X12	SS-400H-107	SPEED INCREASER PROTECTIVE COVER
SS-400H-75	POTENTIOMETER C104	SS-400H-108	FLEXIBLE SHAFT
SS-400H-76	BLADE 18TPI - PINLESS	SS-400H-109	SPEED INCREASER SAFETY COVER
SS-400H-77	PHILIPS SCREW & SPRING WASHER & FLAT WASHER ASSY M6X10	SS-400H-110	ELASTIC CYLINDRICAL PIN 3X8
SS-400H-78	PHILIPS SCREW & FLAT WASHER ASSY M5X8	SS-400H-111	COG BELT 74XXL
SS-400H-79	FOOT PEDAL SWITCH	SS-400H-112	BIG BELT WHEEL
SS-400H-80	CHANGE OVER SWITCH	SS-400H-113	PHILIPS SCREW & SPRING WASHER ASSY M5X28
SS-400H-81	BLADE LOWER BRACKET	SS-400H-114	HEXAGON LOCK NUT M5
SS-400H-82	FIXED NUT	SS-400H-115	HEXAGON LOCK NUT M6
SS-400H-83	PHILIPS SCREW M6X25	SS-400H-116	RUBBER FOOT
SS-400H-84	POWER LIGHT	SS-400H-117	HEXAGON BOLT M6X80
SS-400H-85	BLADE CLAMP	SS-400H-118	KITS BOX 64PCS
SS-400H-86	FLAT WASHER D6 PVC	SS-400H-119	BATTERY AAA
SS-400H-88	HEXAGON SOCKET SET SCREW M5X8	SS-400H-120	ADAPTER BONNET
SS-400H-90	BLADE GUARD	SS-400H-121	PHILIPS SCREW M4X8
SS-400H-91	HEXAGON BOLT & SPRING WASHER ASSY M8X16	SS-400H-122	HEX NUT M4
SS-400H-92	SPRING WASHER D10	SS-400H-123	TOOL BOX ON THE SIDE COVER
SS-400H-93	LAMP POLE		
SS-400H-94	LAMP ASSY		

Variable Speed  
Scroll Saw  
SS-400H

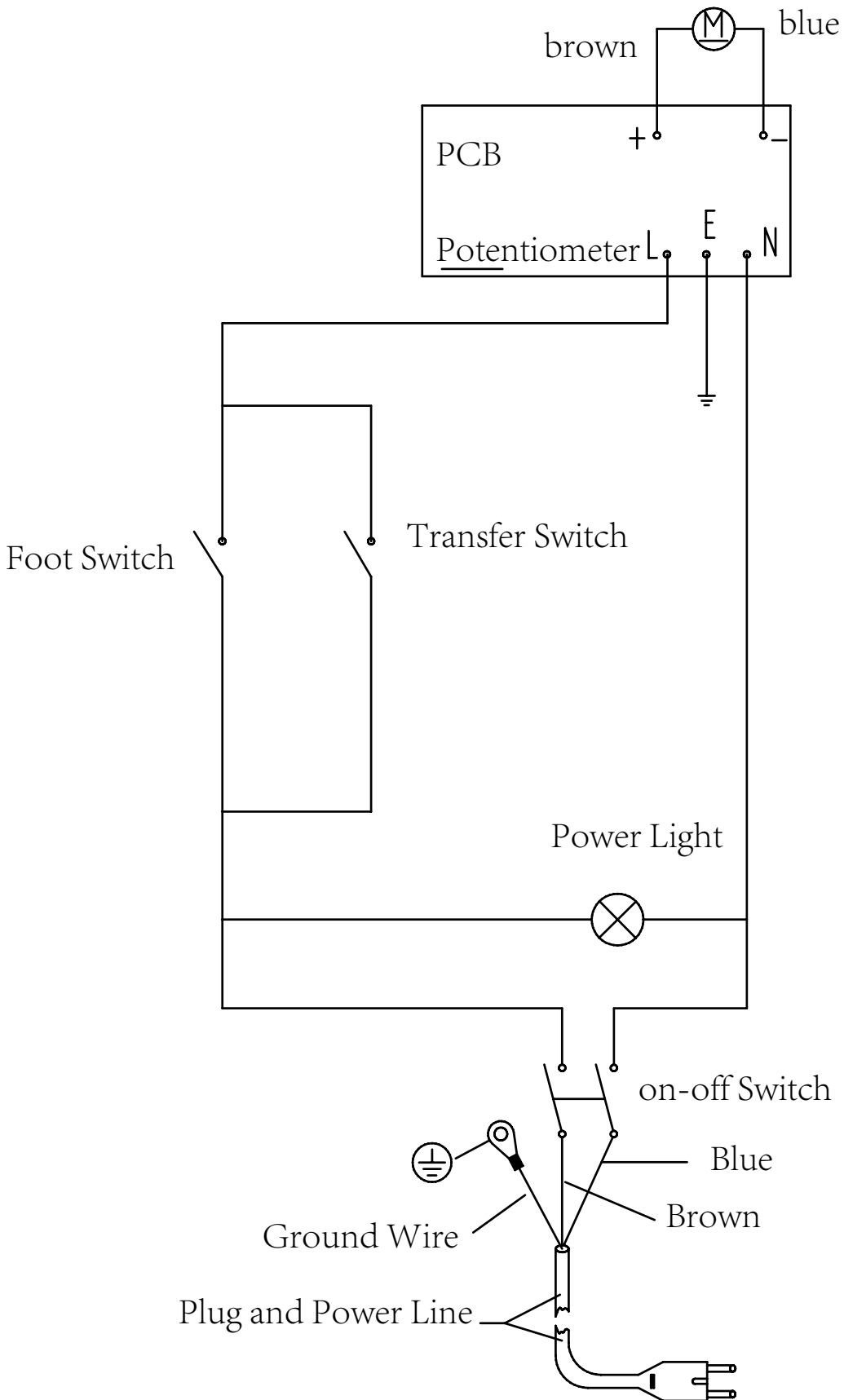



# 1 YEAR WARRANTY

## WARRANTY

- A. We warrant that this Carbatec product will be free from defects caused by faulty workmanship or faulty materials for a period of 1 year from date of sale.
- B. This warranty is in addition to other rights and remedies you may have under a law in relation to the goods.
- C. This warranty does not apply in any of the following cases:
- i. Defects arising from:
    1. fair wear and tear;
    2. corrosive atmosphere;
    3. damage or injury caused by deliberate act, lack of care or failure to comply with the recommended care and maintenance for the goods;
    4. improper use of the goods;
    5. alterations or repairs (not made by us) to the goods;
  - ii. defects arising from an event outside of our control such as fire, flood, earthquake or other natural calamity, motor vehicle or other accident, strike, civil unrest, terrorism or war;
  - iii. to accessory items such as after-market jigs, accessories or other items which are not sold or serviced by us and which are not sold with or were not included with the main unit purchased; or
  - iv. to wearable parts such as drive belts/shafts, bearings, bandsaw tyres, motor brushes, blades or abrasive belts/discs or other cutting or machining implements.
  - v. damage caused to any electrical component, where connected to a power supply outside the country for which it was designed (namely Australia or New Zealand).
- D. If this warranty applies and you have complied with the procedure below for making a claim, we will, at our election, either repair the goods (or those parts of the goods recognised as defective) or will provide a replacement within a reasonable time at our expense.
- E. If this warranty applies, the procedure for making a claim is:
- i. you must contact us by email;
  - ii. you must include in the email the following information:
    1. a copy of the order or receipt for the goods;
    2. the serial or batch number printed on the machinery manufacturing plate; and
    3. a detailed description of the fault and how and when it arose; and
  - iii. If the fault is a type covered by this warranty, we will then make arrangements with you for the return of the goods to us (for repair or replacement) at our cost using our transport providers or we may decide to attend at your premises to repair or replace the goods.
- F. Our liability (and that of our resellers) under this warranty is wholly limited to repair or replacement of the goods (or those parts of the goods recognised as defective) in accordance with the procedure above and you have no right to other compensation, costs or damages under this warranty. But this does not mean that you may not have other rights under a law in relation to the goods.
- G. If following our inspection of goods returned by you under this warranty it is found that this warranty does not apply and you are not otherwise entitled to repair or replacement by us, you must, if requested by us, reimburse our costs including parts, labour and freight.
- H. This warranty is not transferable and only the person who purchased the goods may make a claim.
- I. Where the goods have been exported outside Australia or New Zealand, the Company may not require the Purchaser to return any allegedly faulty or defective Product for evaluation. However, the Company has the right to request the return for evaluation at purchasers cost.

## STATUTORY NOTICE

Our goods come with guarantees that cannot be excluded under the Australian Consumer Law. You are entitled to a replacement or refund for a major failure and for compensation for any other reasonably foreseeable loss or damage. You are also entitled to have the goods repaired or replaced if the goods fail to be of acceptable quality and the failure does not amount to a major failure.

# TROUBLESHOOTING

**TO PREVENT INJURY TO YOURSELF** or damage to the Scroll Saw, turn the switch to the "OFF" position and unplug the power cord from the electrical receptacle before making any adjustments.

PROBLEM	LIKELY CAUSE(S)	SOLUTION(S)
<b>Saw blades break</b>	<ol style="list-style-type: none"> <li>1. Tension incorrectly set</li> <li>2. Load too great</li> <li>3. Incorrect saw blade variety</li> <li>4. Workpiece not fed straight</li> </ol>	<ol style="list-style-type: none"> <li>1. Set the correct tension</li> <li>2. Feed the workpiece more slowly</li> <li>3. Use the correct saw blades</li> <li>4. Avoid exerting pressure from the side</li> </ol>
<b>Motor does not function</b>	<ol style="list-style-type: none"> <li>1. Mains Gable faulty</li> <li>2. Motor faulty</li> </ol>	<ol style="list-style-type: none"> <li>1. Change faulty parts</li> <li>2. Call customer service. <b>Do not attempt to repair the motor yourself as this should be carried out by trained personnel.</b></li> </ol>
<b>Vibration</b> <b>NOTE:</b> The saw vibrates slightly when the motor is running in normal operation.	<ol style="list-style-type: none"> <li>1. Saw incorrectly installed</li> <li>2. Unsuitable underlay</li> <li>3. The work bench is not screwed down or is on the motor</li> <li>4. The motor is not secured</li> </ol>	<ol style="list-style-type: none"> <li>1. Refer to the instructions given earlier in this manual for information on installing the saw</li> <li>2. The heavier the work bench is, the less the vibration. A bench made from ply wood always vibrates more than one made from solid wood. Select the work bench best suited to your working conditions</li> <li>3. Tighten the locking lever</li> <li>4. Securely screw the motor in place</li> </ol>
<b>Saw blade swings out Holders not aligned straight</b>	<ol style="list-style-type: none"> <li>1. Holders not aligned</li> </ol>	<ol style="list-style-type: none"> <li>1. Loosen the screws with which the holders are fastened to the arm. Align the holders so that they are perpendicular to each other and re-tighten the screws.</li> </ol>

# REPLACEMENT BLADES



## SCROLL SAW BLADE SELECTION CHART

This scroll saw blade selection chart is a base for any woodworker, from someone who wants to begin scrolling and doesn't know which blade to select, to an experienced scroller looking for a perfect fit for their project. Additional technical information is available on our product packaging and online.

Pegas are blade manufacturing specialists from Switzerland. Their products are recognised by professionals and individuals alike as the best Scroll Saw blades available, outperforming and outlasting competition in testing. Carbatec are proud to offer these blades to the Australian market.

### SUPER-SKIP

Use the new Pegas®Super-Skip saw blade when you want to achieve a smooth finish from an aggressive blade. Specially designed for hard and medium-hardwoods, Super-Skip also works perfectly on Acrylic with a reduced speed. The spaces between the teeth of the Super-Skip blade are wider than the normal skip-tooth configuration. This enables the blade to cut very quickly, leaving a smooth finish. The surface sawdust is whisked away and the edge remains clean.

SKU	Universal #	Blade Thickness (mm)	Blade Width (mm)	TPI (in.)	Kerf (mm)							Optimal Material Thickness (mm)	Intricate Cuts	Tight Turns	Light Turns	
						Hardwoods	Medium Hardwoods	Softwoods	Plywood	Corian - Plastics	Alum., Brass, Copper					Ferrous Materials
PEG-90-581	1	0.26	0.76	17.2	0.29	Green	Green	Yellow	Yellow	Green	Red	Red	2.5-8	●		
PEG-90-583	3	0.32	0.85	14.8	0.35	Green	Green	Yellow	Yellow	Green	Red	Red	4-10	●		
PEG-90-585	5	0.36	1.02	12.8	0.4	Green	Green	Yellow	Yellow	Green	Red	Red	8-15		●	
PEG-90-587	7	0.4	1.24	11.3	0.45	Green	Green	Yellow	Yellow	Green	Red	Red	10-20		●	
PEG-90-589	9	0.44	1.3	10.1	0.49	Green	Green	Yellow	Yellow	Green	Red	Red	12-25			●

### SKIP

Universal Scroll saw blade, very efficient in Hard and Medium-Hard woods. The wide range of skip allows the cutting of intricate patterns as well as rough-cut work. It will accept a fast feed rate and will leave a smooth finish.

SKU	Universal #	Blade Thickness (mm)	Blade Width (mm)	TPI (in.)	Kerf (mm)							Optimal Material Thickness (mm)	Intricate Cuts	Tight Turns	Light Turns	
						Hardwoods	Medium Hardwoods	Softwoods	Plywood	Corian - Plastics	Alum., Brass, Copper					Ferrous Materials
PEG-90-401	0	0.24	0.74	25.4	0.26	Green	Green	Yellow	Yellow	Green	Red	Red	2-6	●		
PEG-90-403	2	0.3	0.78	21	0.33	Green	Green	Yellow	Yellow	Green	Red	Red	3-10	●		
PEG-90-405	4	0.34	0.95	18.1	0.38	Green	Green	Yellow	Yellow	Green	Red	Red	5-12		●	
PEG-90-407	6	0.38	1.12	15.9	0.42	Green	Green	Yellow	Yellow	Green	Red	Red	8-18		●	
PEG-90-409	8	0.42	1.28	14.1	0.47	Green	Green	Yellow	Yellow	Green	Red	Red	12-20			●
PEG-90-411	10	0.46	1.38	12.7	0.52	Green	Green	Yellow	Yellow	Green	Red	Red	15-30			●
PEG-90-413	12	0.5	1.55	11.5	0.56	Green	Green	Yellow	Yellow	Green	Red	Red	20-50			●

**PINNED BLADES**

Pegas offer a range of 'Pinned' blades, designed for use on Scroll Saw's with chuck heads suited to this style. Pinned blades have a cross pin at each end of the blade and are not suitable for 'Pinless' style chuck heads.

Pinned Regular  
 Pinned Skip  
 Pinned Hook



SKU	Blade Style	Blade Thickness (mm)	Blade Width (mm)	TPI (in.)	Kerf (mm)	Hardwoods	Medium Hardwoods	Softwoods	Plywood	Corian - Plastics	Alum., Brass, Copper	Ferrous Materials	Optimal Material Thickness (mm)	Intricate Cuts	Tight Turns	Light Turns
PEG-90-475	Reg.	0.5	3	20	0.72	Red	Red	Yellow	Yellow	Green	Yellow	Red	4-30			●
PEG-90-476	Reg.	0.5	3	15	0.72	Red	Red	Yellow	Yellow	Green	Yellow	Red	5-35			●
PEG-90-478	Reg.	0.25	2	25	0.4	Red	Red	Yellow	Yellow	Green	Yellow	Red	3-20			●
PEG-90-480	Skip	0.5	3	9	0.72	Red	Red	Yellow	Yellow	Green	Yellow	Red	10-60			●
PEG-90-481	Skip	0.25	2	18.5	0.36	Green	Green	Yellow	Yellow	Yellow	Red	Red	4-30			●
PEG-90-485	Hook	0.5	3	7	0.74	Green	Green	Yellow	Yellow	Yellow	Red	Red	10-75			●

**REGULAR PROGRESSIVE**



The Pegas® Regular Progressive Blade was particularly developed for use in a hand-held saw frame. It is resistant to breakage in this use due to its unique progressive tooth geometry, making for very smooth starting cuts without resistance. These blades are suited to non-ferrous metals and other materials harder than wood.

SKU	Blade Style	Blade Thickness (mm)	Blade Width (mm)	TPI (in.)	Kerf (mm)	Hardwoods	Medium Hardwoods	Softwoods	Plywood	Corian - Plastics	Alum., Brass, Copper	Ferrous Materials	Optimal Material Thickness (mm)	Intricate Cuts	Tight Turns	Light Turns
PEG-90-467	2	0.3	0.78	39.35	N/A	Yellow	Red	Red	Yellow	Green	Green	Red	2-6		●	
PEG-90-468	5	0.36	1.02	29.8	N/A	Yellow	Red	Red	Yellow	Green	Green	Red	3-10		●	

**GENERAL INFORMATION**

The smaller the blade number is, the smaller radius it will cut. The smaller the blade number is, the narrower the kerf will be.

Before starting a new project, ask yourself these questions:

- What type of material am I cutting?
- How thick is the piece of material?
- How thin does the cut line need to be (Puzzle, Intarsia)?

**LEGEND**

RECOMMENDED	OK TO USE	NOT RECOMMENDED







## **Carbatec Pty Ltd**

**E** [info@carbatec.com.au](mailto:info@carbatec.com.au)

**AU** 1800 658 111

**NZ** 0800 444 329

1/364 New Cleveland Rd, Tingalpa QLD 4173

Australia

ABN 84 010 706 242

**[carbatec.com.au](http://carbatec.com.au)**

**carbatec®**

**1** YEAR  
WARRANTY