

carbatec®



**TS-C250PX
CARBATEC DELUXE 10"
CABINET TABLE SAW**

INSTRUCTIONS MANUAL

carbatec.com.au

2 YEAR
WARRANTY

THANK YOU FOR CHOOSING carbatec®

Carbatec has been a trusted brand for woodworking enthusiasts and professionals across Australia and New Zealand, since 1987.



Our quality woodworking products are designed and built to offer value and performance, making the latest features and technological advancements more accessible to Aussie woodworkers.

Backed by our no-fuss after-sales care and warranty support, you can trust Carbatec to keep you woodworking, as promised.

We look forward to sharing in your woodworking journey!

If you have any questions about our products or service, please call us on 1800 658 111 or email us at info@carbatec.com.au

Find us on social media

-  facebook.com/Carbatec
-  instagram.com/Carbatec
-  youtube.com/CarbaTecToolsForWood

CONTENTS

Introduction	2
Specifications	4
What's in the box	5-7
Key information	8
Safety instructions - General	9-13
Safety instructions - Table saw	14
Safety instructions - Electrical	15
Overview	16
Installation	17-18
Assembly	19-23
Adjustments	24-25
Operation	26-27
Maintenance	28
Troubleshooting	29
Parts diagram and parts lists	30-36
Wiring diagram	37
Warranty	39

NOTE: The specifications, photographs, drawings and information in this manual represent the current machine model when the manual was prepared. Changes and improvements may be made at any time, with no obligation on the part of Carbatec to modify previously delivered units. Reasonable care has been taken to ensure that the information in this manual is correct, to provide you with the guidelines for the proper safety, assembly and operation of this machine.

SPECIFICATIONS

BRAND		Carbatec
MOTOR	TYPE	TEFC, Capacitor Start, Induction
	POWER	2.3 KW Input / 1.8 Kw Output 10 amp
	SPEED	2850 RPM (50HZ)
	POWER TRANSFER	V-Ribbed Belt Drive
SWITCH	TYPE	Magnetic with Thermal Overload Protection
	STANDARD	Australian 
BLADE	MAX. BLADE DIAMETER	254 mm (10")
	RIVING KNIFE THICKNESS	2.5 mm (0.1")
	BLADE PLATE THICKNESS	1.8-2.4 mm (0.071"-0.094")
	BLADE KERF THICKNESS	2.6-3.2 mm (0.102"-0.126")
	MAX. WIDTH OF DADO	20.6 mm (13/16")
	BLADE TILT	Left 0-45°
	ARBOR BEARING	Sealed and Permanently Lubricated
CUTTING CAPACITIES	MAX. DEPTH OF CUT AT 90°	76 mm (3")
	MAX. DEPTH OF CUT AT 45°	52 mm (2")
	MAX. RIP, RIGHT OF BLADE	762 mm (30")
	MAX. RIP, LEFT OF BLADE	315 mm (12.5")
TABLE	HEIGHT FROM FLOOR	888 mm (35")
	DIMENSIONS (L x W x Thickness)	685 x 510 x 40 mm (27" x 20-1/8" x 1-6/10")
	WITH EXTENSIONS	1360 mm wide
MITER GAUGE	SLOT TYPE	T-SLOT
	SIZE (Width x Height)	19.05 x 9.5 mm (3/4" x 3/8")

WHAT'S IN THE BOX

This machine will require a minimal amount of assembly.

1. Remove parts from all of the cartons and lay them on a clean work surface.
2. Remove any protective materials and coatings from the machine and from all of the parts. The protective coatings can be removed by spraying WD-40 on them and wiping it off with a soft cloth. This may need to be redone several times before all of the protective coatings are removed completely.
3. Compare the items above to verify that all items are accounted for before discarding the shipping box.

! CAUTION

DO NOT use acetone, gasoline or lacquer thinner to remove any protective coatings.

! WARNING

If any parts are missing, do not attempt to plug in the power cord and turn "ON" the machine. The machine can only be turned "ON" after all the parts have been installed correctly.

The following items are provided in four shipping boxes:

MAIN BOX CONTENTS - Fig 1 to 5

- | | | |
|--|---------------------------------------|--------------------------------|
| A. Main table saw unit x 1 | F. Blade guard assembly x 1 | L. Fence rest arms x 1 |
| B. Motor cover x 1 | G. Hex wrench set (3 pces) x 1 | M. Dado insert x 1 |
| C. Left extension wing x 1 | H. Open wrench (2 pces) x 1 | N. Miter gauge x 1 |
| D. Extension table (width 365 mm) x 1 | I. Hand wheel handles x 2 | P1. Outer dust port x 1 |
| E. Riving knife x 1 | J. Arbor wrench x 1 | P2. Inner dust port x 1 |
| | K. Push stick x 1 | |

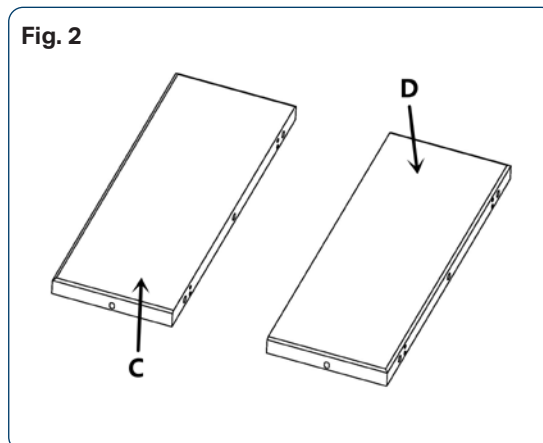
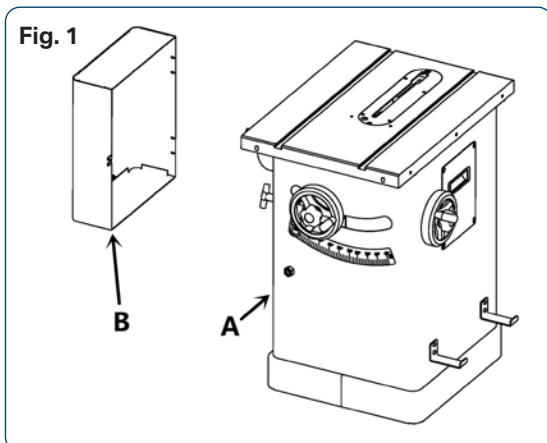

WHAT'S IN THE BOX

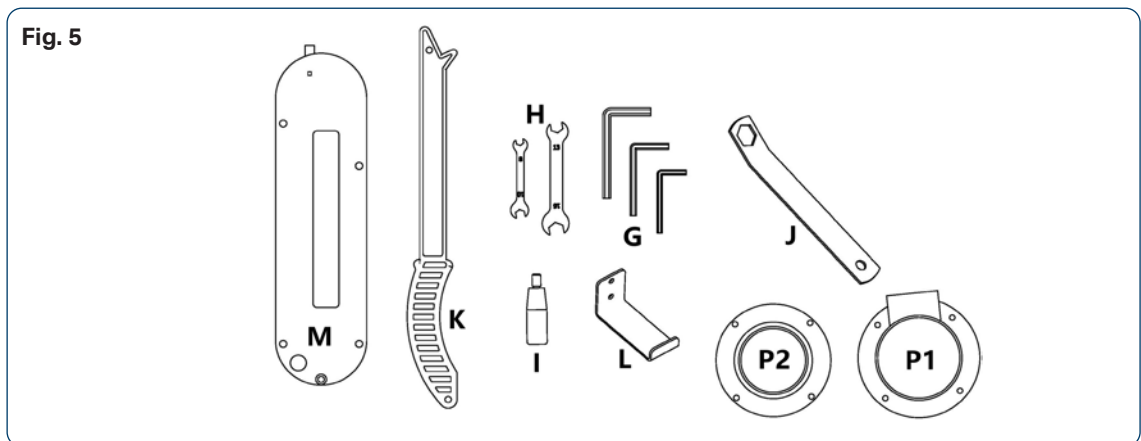
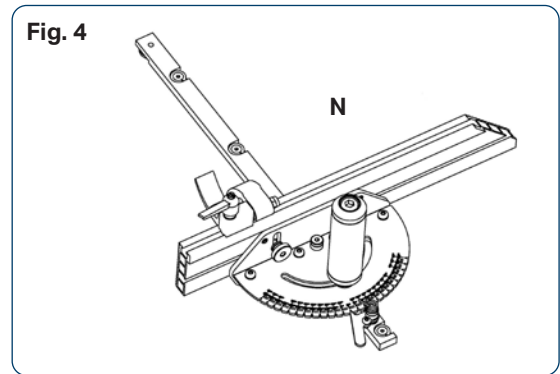
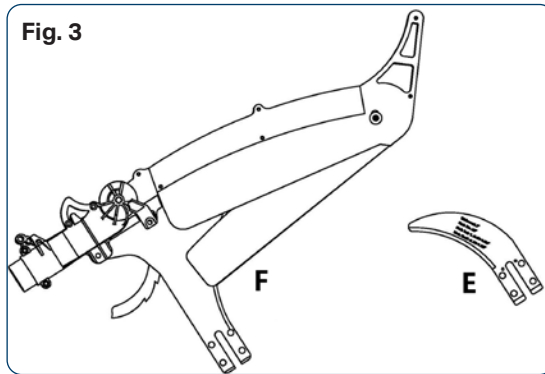

6

FENCE BOX CONTENTS - Fig. 6

- A.** Fence body x 1
- B.** Fence x 1

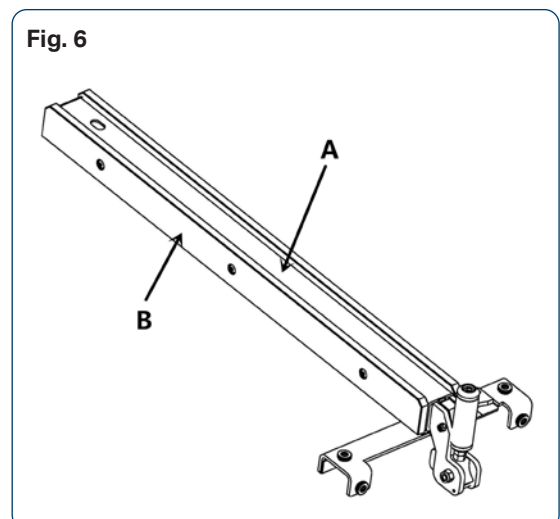

WHAT'S IN THE BOX

UPPER DUST EXTRACTION TUBE CONTENTS - Fig. 7

- A. Over arm x 1
- B. Flexible hose (length 0.6 m) x 1
- C. Flexible hose (length 1 m)
- D. Bracket x 2

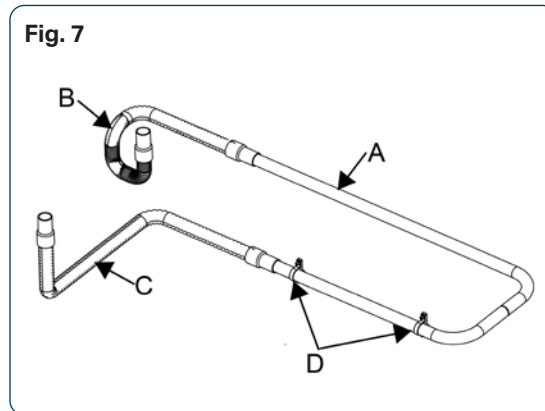

RAIL BOX CONTENTS - Fig. 8

- A. Rear rail x 1
- B. Front rail x 1
- C. Front rail rectangular tube x 1
- D. Front rail tape scale (not shown) x 1

Note: The assembly contains the corresponding hardware which is not shown in the figure, and can be checked with the exploded view.

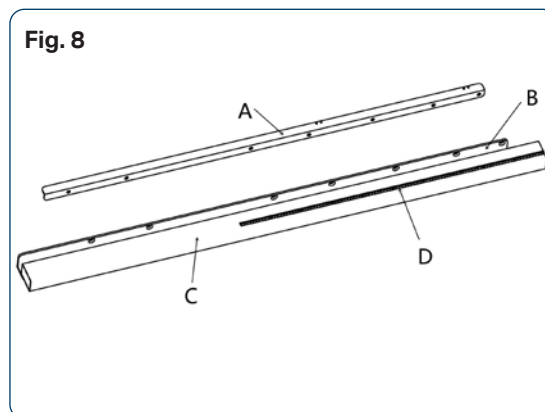

IMPORTANT

DUST COLLECTION: All woodworking machines require effective dust extraction to ensure quality work and longevity of the machine itself. Failure to connect your machine to a suitable dust collector may affect your warranty. The collector required for your machine will depend on several factors including the type of machine and its dust port connection, distance between collector and machine, type and frequency of use and the material being worked. We recommend a dust collector that will provide you a minimum airflow of 500-CFM when measured at the machine connection.

Key information can be found on the inspection panel, found on the rear of the machine.

8



QUALITY INSPECTED

Model:
Voltage
Freq:
Phase:
Amp:
kW:
Speed:
Lot No.:
Serial No.:
Date:

Made in **CARBATEC PTY LTD**
Brisbane - Australia

for:





Record the serial number and date of purchase in your manual for future reference.

SERIAL NUMBER:

.....

DATE OF PURCHASE:

SAFETY INSTRUCTIONS

IMPORTANT! Safety is the single most important consideration in the operation of this equipment. The following instructions must be followed at all times. Failure to follow all instructions listed below may result in electric shock, fire, and/or serious personal injury. There are certain applications for which this tool was designed. We strongly recommend that this tool not be modified and/or used for any other application other than that for which it was designed. If you have any questions about its application, do not use the tool until you have contacted us and we have advised you.

The purpose of safety symbols is to attract your attention to possible dangers. The safety symbols and the explanations with them deserve your careful attention and understanding. The symbol warnings do not, by themselves, eliminate any danger. The instructions and warnings they give are no substitutes for proper accident prevention measures.

WARNING

Be sure to read and understand all safety instructions in this manual, including all safety alert symbols such as "DANGER," "WARNING," and "CAUTION" before using this tool. Failure to following all instructions listed below may result in electric shock, fire, and/or serious personal injury.

SYMBOL MEANING



A safety alert symbol Indicates **DANGER, WARNING, or CAUTION.** May be used in conjunction with other symbols or pictographs.



DANGER

Indicates an imminently hazardous situation, which, if not avoided, will result in death or serious injury.



WARNING

Indicates a potentially hazardous situation, which, if not avoided, could result in death or serious injury.



CAUTION

Indicates a potentially hazardous situation, which, if not avoided, could result in minor or moderate injury.

NOTICE

(Without Safety Alert Symbol) Indicates a situation that may result in property damage.



Carbatec products bearing the Regulatory Compliance Mark (RCM) have been tested in accordance with applicable Australian/New Zealand Standards to ensure their compliance with all mandatory standards and regulations (applicable at time of original sale). Carbatec Pty Ltd are registered as a responsible supplier with relevant Australian government departments and our products are registered on the EESS & ACMA database.

GENERAL SAFETY

Operating a power tool can be dangerous if safety and common sense are ignored. The operator must be familiar with the operation of this machine. Read this manual to understand this machine. **DO NOT OPERATE** this machine **IF YOU DO NOT FULLY UNDERSTAND** the limitations of this tool. **DO NOT MODIFY** this machine in any way.

BEFORE USING THIS MACHINE



WARNING

To avoid serious injury and damage to the tool, read and follow all of the Safety and Operating Instructions before operating the machine.



WARNING

1. **SOME DUST CREATED BY USING POWER TOOLS CONTAINS CHEMICALS** known to cause cancer, birth defects, or other reproductive harm. Some examples of these chemicals are:
 - Lead from lead-based paints.
 - Crystalline silica from bricks, cement, and other masonry products.
 - Arsenic and chromium from chemically treated lumber

Your risk from these exposures varies, depending on how often you do this type of work. To reduce your exposure to these chemicals: work in a well ventilated area and work with approved safety equipment, such as those dust masks that are specially designed to filter out microscopic particles.

2. **READ** this entire manual. **LEARN** how to use the tool for its intended applications.
3. **GROUND ALL TOOLS.** If the tool is supplied with a 3-prong plug, it must be plugged into a 3-contact electrical receptacle. The third prong is used to ground the tool and provide protection against accidental electric shock.
4. **AVOID A DANGEROUS WORKING ENVIRONMENT.** Do not use electrical tools in a damp environment or expose them to rain.
5. **DO NOT USE** electrical tools in the presence of **FLAMMABLE** liquids or gases.
6. **ALWAYS KEEP THE AREA CLEAN,** well lit, and organized. Do not work in an environment with floor surfaces that are slippery from debris, grease, and wax.
7. **KEEP VISITORS AND CHILDREN AWAY.** Do not permit people to be in the immediate work area, especially when the electrical tool is operating.
8. **DO NOT FORCE THE TOOL** to perform an operation for which it was not designed. It will do a safer and higher quality job by only performing operations for which the tool was intended.

GENERAL SAFETY

9. WEAR PROPER CLOTHING.

Do not wear loose clothing, gloves, neckties, or jewellery. These items can get caught in the machine during operations and pull the operator into the moving parts. The user must wear a protective cover on their hair, if hair is long, to prevent it from contacting any moving parts.

10. CHILDPROOF THE WORKSHOP AREA by removing switch keys, unplugging tools from the electrical receptacles, and using padlocks.

11. ALWAYS UNPLUG THE TOOL FROM THE ELECTRICAL RECEPTACLE when making adjustments, changing parts or performing any maintenance.

12. KEEP PROTECTIVE GUARDS IN PLACE AND IN WORKING ORDER.

13. AVOID ACCIDENTAL STARTING. Make sure that the power switch is in the "OFF" position before plugging in the power cord to the electrical receptacle.

14. REMOVE ALL MAINTENANCE TOOLS from the immediate area prior to turning "ON" the machine.

15. USE ONLY RECOMMENDED ACCESSORIES. Use of incorrect or improper accessories could cause serious injury to the operator and cause damage to the tool. If in doubt, check the instruction manual that comes with that particular accessory.

16. NEVER LEAVE A RUNNING TOOL UNATTENDED. Turn the power switch to the "OFF" position. Do not leave the tool until it has come to a complete stop.

17. DO NOT STAND ON A TOOL. Serious injury could result if the tool tips over, or you accidentally contact the tool.

18. DO NOT STORE ANYTHING ABOVE OR NEAR the tool where anyone might try to stand on the tool to reach it.

19. MAINTAIN YOUR BALANCE. Do not extend yourself over the tool. Wear oil resistant rubber soled shoes. Keep floor clear of debris, grease, and wax.

20. MAINTAIN TOOLS WITH CARE. Always keep tools clean and in good working order. Keep all blades and tool bits sharp, dress grinding wheels and change other abrasive accessories when worn.

21. EACH AND EVERY TIME, CHECK FOR DAMAGED PARTS PRIOR TO USING THE TOOL. Carefully check all guards to see that they operate properly, are not damaged, and perform their intended functions. Check for alignment, binding or breaking of moving parts. A guard or other part that is damaged should be immediately repaired or replaced.

22. DO NOT OPERATE TOOL WHILE TIRED, OR UNDER THE INFLUENCE OF DRUGS, MEDICATION OR ALCOHOL.

GENERAL SAFETY

- 23. SECURE ALL WORK.** Use clamps or jigs to secure the work piece. This is safer than attempting to hold the work piece with your hands.
- 24. STAY ALERT, WATCH WHAT YOU ARE DOING, AND USE COMMON SENSE WHEN OPERATING A POWER TOOL.** A moment of inattention while operating power tools may result in serious personal injury.
- 25. ALWAYS WEAR A DUST MASK TO PREVENT INHALING DANGEROUS DUST OR AIRBORNE PARTICLES,** including wood dust, crystalline silica dust and asbestos dust. Direct particles away from face and body. Always operate tool in well ventilated area and provide for proper dust removal. Use dust collection system wherever possible. Exposure to dust may cause serious and permanent respiratory or other injury, including silicosis (a serious lung disease), cancer, and death. Avoid breathing dust, and avoid prolonged contact with dust. Allowing dust to get into your mouth or eyes, or lay on your skin may promote absorption of harmful material. Always use properly fitting AS/NZS approved respiratory protection appropriate for the dust exposure, and wash exposed areas with soap and water.
- 26. USE A PROPER EXTENSION CORD IN GOOD CONDITION.** Use of extension cords should be avoided where possible. When using an extension cord, be sure to have a cord heavy enough to carry the current your product will draw, and with compatible pin configuration and connections (NEVER use an extension cord rated at less than your machine). Longer run extensions will need heavier duty extension cords. Only connect your extension cord or machine to a receptacle that accepts your plug and never modify your plug to suit a receptacle.

GENERAL SAFETY

NOTE: According to the applicable product liability law the manufacturer of this device is not liable for damages which arise on or in connection with this device in case of:

- Improper handling
- Non-compliance with the instructions for use
- Repairs by third party, non authorised skilled workers
- Installation and replacement of non-genuine spare parts
- Improper use

RECOMMENDATIONS:

- Read the entire text of the operating instructions prior to the assembly and operation of the device. These operating instructions are intended to make it easier for you to get familiar with your device and utilise its intended possibilities of use.
- The operating instructions contain important notes on how to work safely with your machine and how to avoid dangers, and increase the reliability and working life of the machine.
- Retain and store these instructions near the machine. The instructions must be read and carefully observed by each operator prior to starting the work.
- In addition to the safety notes contained in the present operating instructions and the special regulations of your country, the generally recognised technical rules for the operation of wood working machines must be observed.



The device and packaging materials are not toys! Children must not be allowed to play with plastic bags, film and small parts! There is a risk of swallowing and suffocation!

INTENDED USE

- The machine must only be used in technically perfect condition in accordance with its designated use and the instructions set out in the operating manual, and only by safety-conscious persons who are fully aware of the risks involved in operating the machine. Any functional disorders, especially those affecting the safety of the machine, should therefore be rectified immediately. The safety, work and maintenance instructions of the manufacturer as well as the technical data given in the calibrations and dimensions must be adhered to.
- Relevant accident prevention regulations and other, generally recognised safety-technical rules must also be adhered to.
- The machine may only be used, maintained, and operated by persons familiar with it and instructed in its operation and procedures. Arbitrary alterations to the machine release the manufacturer from all responsibility for any resulting damages.
- The machine may only be used with original accessories and tools made by or recommended by the manufacturer.
- Any other use exceeds authorisation. The manufacturer is not responsible for any damages resulting from unauthorized use; risk is the sole responsibility of the operator.

SAFETY FOR TABLE SAWS

- 1. ALWAYS USE A GUARD**, splitter on all “thru-sawing” operations (when the blade cuts completely through the work piece as in ripping or crosscutting).
- 2. ALWAYS HOLD THE WORK** firmly against the miter gauge or fence.
- 3. ALWAYS USE A PUSH STICK OR PUSH BLOCK** when cutting small workpieces and in circumstances where it is necessary to push the workpiece against the fence;
- 4. NEVER PERFORM UNSAFE OPERATIONS** using your hands to support or guide the work piece. Always use either the fence or the miter gauge .
- 5. STAND TO THE SIDE WHEN FEEDING MATERIAL.** Never stand or have any part of your body in line with the path of the saw blade.
- 6. USE CAUTION WHEN REACHING FOR OBJECTS.** Never reach behind or over the cutting tool with either hand for any reason.
- 7. SAFE CROSSCUTTING OPERATIONS.** Move the rip fence out of the way when crosscutting.
- 8. ENSURE CORRECT FEEDING OF MATERIAL.** Feed the work into the blade against the direction of rotation.
- 9. CORRECT USAGE WITH THE FENCE.** Never use the fence as a cut-off gauge when you are cross-cutting.
- 10. ALWAYS TURN THE POWER TO THE “OFF” POSITION** when attempting to free a stalled saw blade.
- 11. PROVIDE ADEQUATE SUPPORT** to the rear and sides of the table saw for wide or long work pieces.
- 12. AVOID KICKBACKS** (work thrown back towards you) by:
 - keeping the blade sharp,
 - keeping the rip fence parallel to the saw blade,
 - keeping the splitter and guard in place when operating,
 - not releasing work before it is pushed all the way past the saw blade,
 - not ripping work that is twisted, warped or does not have a straight edge to guide along the fence.
- 13. AVOID AWKWARD OPERATIONS** and hand positions where a sudden slip could cause your hand to move into the spinning blade.
- 14. CORRECT SAW BLADE USAGE.** No saw blade shall be used where the maximum marked speed is lower than the maximum rotational speed of the saw spindle.
- 15. CHIP AND DUST.** The machine shall be connected to an external chip and dust extraction system. The dust extraction equipment is to be switched on before commencing machining.
- 16. PERIODICALLY CHECK STOP TIME OF BLADE** to make sure the completed stop time of the saw blade is less than 10 seconds.

ELECTRICAL SAFETY

WARNING

This tool must be grounded while in use to protect the operator from electric shock. IN THE EVENT OF A MALFUNCTION OR BREAKDOWN, grounding provides the path of least resistance for electric current and reduces the risk of electric shock. This tool may be equipped with an electric cord that has an equipment grounding conductor and a grounding plug. **The plug MUST Be plugged** into a matching electrical receptacle that is properly installed and grounded in accordance with **ALL** local codes and ordinances.

DO NOT MODIFY THE PLUG PROVIDED.

If it will not fit the electrical receptacle, have the proper electrical receptacle installed by a qualified electrician.

IMPROPER ELECTRICAL CONNECTION of the equipment grounding conductor can result in risk of electric shock. The conductor with the green insulation (with or without yellow stripes) is the equipment grounding conductor. **DO NOT** connect the equipment grounding conductor to a live terminal if repair or replacement of the electric cord or plug is necessary.

CHECK WITH A QUALIFIED ELECTRICIAN

or service personnel if you do not completely understand the grounding instructions, or if you are not sure the tool is properly grounded.

Use only a 3-wire extension cord that has a 3-prong grounding plug and a 3-pole receptacle that accepts the tool's plug. Replace a damaged or worn cord immediately.

Power tools and machinery are intended for use on a circuit that has an electrical receptacle as shown in **FIGURE A** that shows a 10 Amp 3-wire electrical plug and corresponding electrical receptacle that has a grounding conductor.

If this particular tool has been designed and fitted with a two prong electrical plug, ensure it displays the 'Double Insulated' logo shown in **FIGURE B**, before connecting to a 3-wire receptacle.

Never modify the standard fitted electrical plugs to fit your receptacle.

WARNING



OVERVIEW

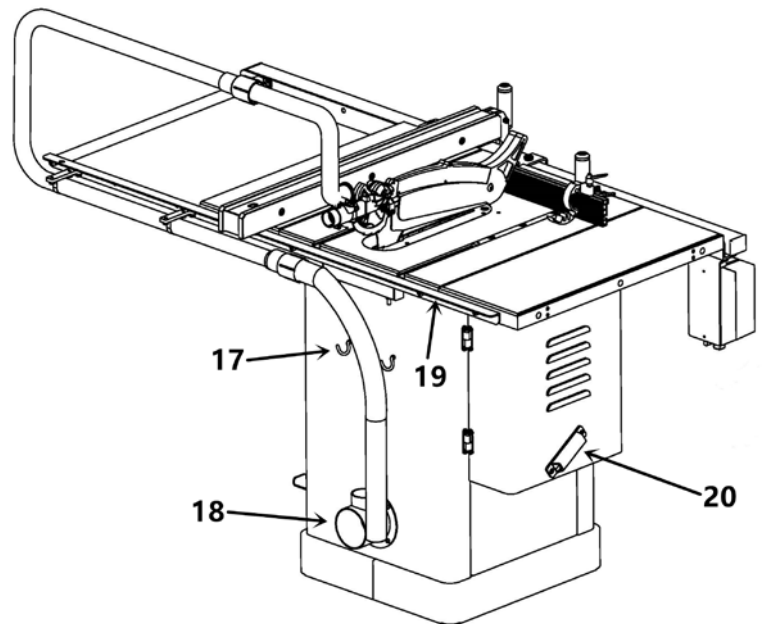
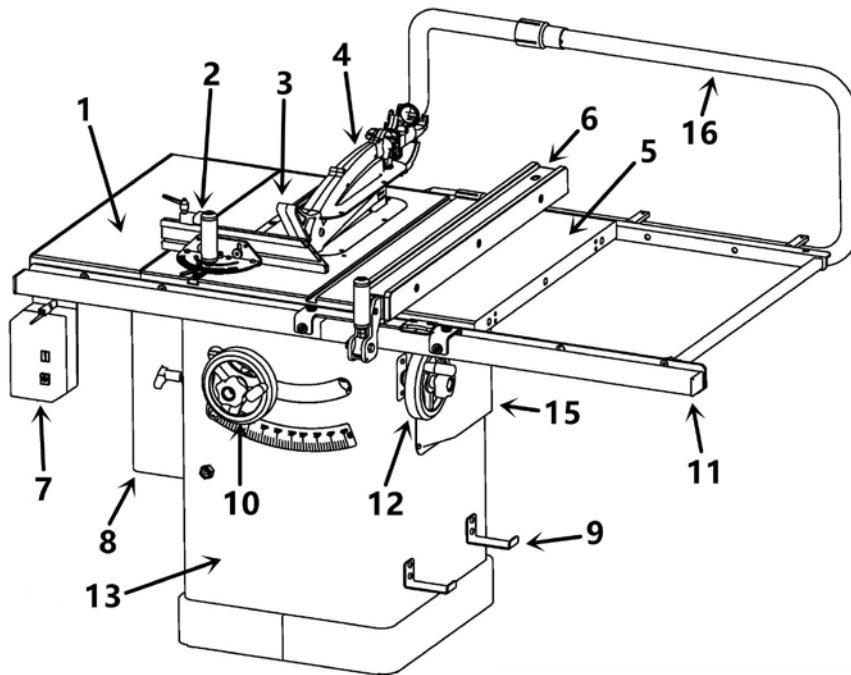

TS-C250PX DELUXE 10" CABINET TABLE SAW

- 1. Left Extension Wing
- 2. Miter Gauge
- 3. Main Table
- 4. Blade Guard
- 5. Right Extension Wing
- 6. Fence
- 7. Magnetic Starter
- 8. Motor Cover
- 9. Fence Rest Arms
- 10. Blade Elevation Hand Wheel
- 11. Front Rail & Tube
- 12. Blade Tilt Hand Wheel
- 13. Cabinet
- 14. Rear Rail
- 15. Service Door
- 16. Dust Collection System
- 17. Tool Hooks
- 18. Dust Port 4"
- 19. Rear Rail
- 20. Miter Gauge Sleeve

INSTALLATION

A. TRANSPORTATION

- This machine has been well packaged and rust preventive measures have been taken at the factory. Care should still be taken to insure that no damage comes from rough handling while moving.
- Ambient temperatures of -25 to 55 can be endured by this machine.
- Be careful not to expose this machine to rain or other severe weather.
- Transporting or handling of the machine should be done by qualified personnel only.
- While the machine is being loaded or unloaded, make sure all persons are out of the way
- Select the proper transportation device according to the weight of the machine.
- This machine is packed in a robust cardboard box and should be transported with a fork lift.



B. UNPACKING

- Remove the packaging materials from around your machine and inspect it. If you discover that the machine is damaged, please immediately call our Customer Service at 1800 658 111.
- Save the containers and all packing materials for possible inspection by the carrier or its agent. Otherwise, filing a freight claim can be difficult.
- If you can't find an item on this list, check the mounting location on the machine or examine the packaging materials carefully. Occasionally we pre-install certain components for shipping purposes, or in other packing.

INSTALLATION

C. INSTALLATION

1. Before beginning assembly, take note of the following precautions:
 - **Level floor:** Make sure the floor is a level surface.
 - **Working clearances:** If any long material is to be cut, it is necessary to have sufficient room both in front of the machine as well as behind it for material infeed and outfeed.
 - **Outlet placement:** Outlets should be located close enough to the machine so that the power cord or extension cord is not in an area where it would cause a tripping hazard.
2. Make sure the machine is not plugged in and the power switch is in the OFF position.
3. Do not connect the machine to the power source until you read and understand this entire instruction manual.
4. Pull the switch out of the saw cabinet and remove the shipping brace. **Fig. C1.**
5. Removing the pallet. The machine is fixed on the pallet by M8 hex bolts. Before installing, please take off the accessories on the pallet and in the cabinet.
6. Move the machine out after removing the set bolts under the pallet. **Fig. C2.**
7. Locate the machine at appropriate place.

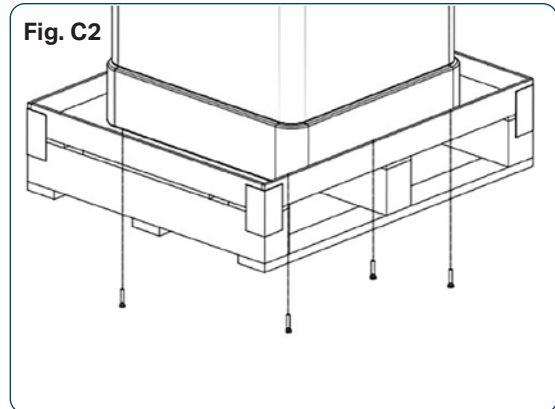
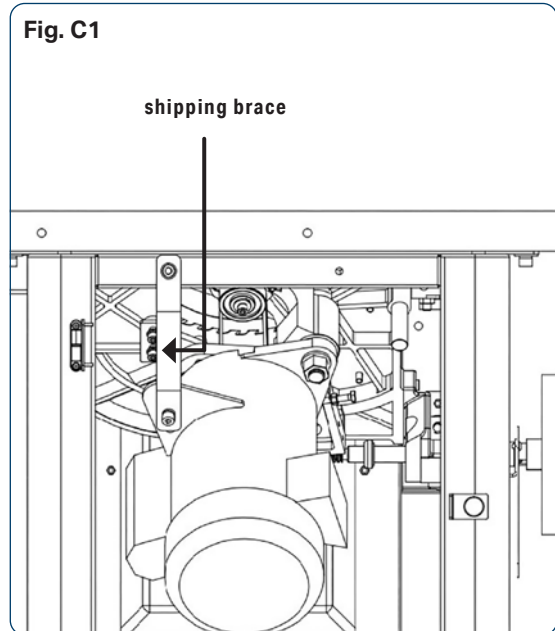

ASSEMBLY

D. HAND-WHEEL INSTALLATION

1. Install the hand-wheel to the cabinet by using the lock knob. **Fig. D1.**
2. Mount the handle to the hand-wheel.

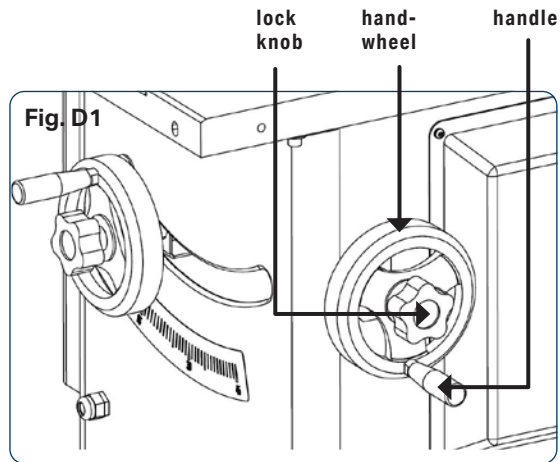

E. EXTENSION WHEEL INSTALLATION

The machine is equipped with a cast iron extension wing on each side of the main table. The mounting bolts of extension wings are pre-mounted in the threaded holes on the main table sides. Install the extension wings as follows:

1. Remove the screws from the sides of the main table.
2. Inspect the extension wings and main table mating surfaces for burrs or foreign materials that may inhibit assembly; the mating edges of the tables must be clean and flat, use a wire brush or sand paper if necessary to clean up the edges.
3. Attach the wings to the main table by using the screws removed in step 1, leaving them a little loose.
4. Use a straightedge to check whether that the main table is coplanar with the extension wing. If not, there are grub screws located beneath the table, on either side of the extension wing, besides the mounting bolts. Adjusting these in or out will adjust the tilt of the table and distance from it, allowing full control over "levelling" your extension wings to the table itself. Once you are satisfied, you can lock the table in place by tightening the mounting bolts.

Fig. E1

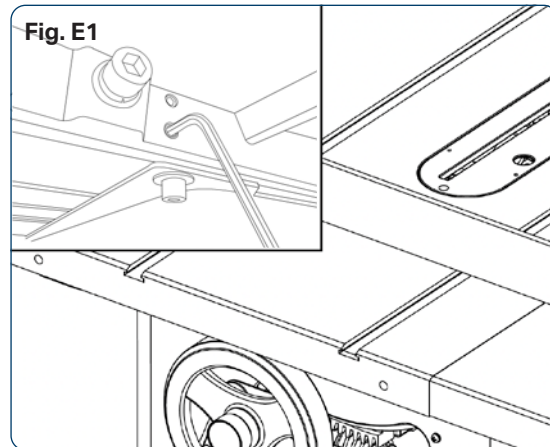

ASSEMBLY

F. RAIL AND EXTENSION TABLE INSTALLATION

1. Before tightening the rear rail, make sure the top edge of the rear rail is lower than the T-slot. **Fig. F1.** Ensure that the extension table is coplanar with the main table.
2. Install the fence on the rail on the right hand side of the blade. Make sure the cam foot contacts the cam on the fence lock handle before you place the fence on the rail, otherwise the fence can not be placed well. **Fig. F2.**
3. Check the parallelism and perpendicularity of the fence. **Fig.F3.** Ensure that the fence is parallel to the miter slot, which is parallel to the blade at any locations. Make sure that the distance $L1 > L2$, $L1 - L2 < 1/64"$, which creates a slightly larger opening between the fence and the blade, at the rear of the blade, to reduce the risk of workpiece binding or burning as it is fed through the cut.
4. Adjust the parallelism and perpendicularity of the fence. **Fig. F4.** If the fence or blade is not parallel to the T-slot, or the fence is not perpendicular to the table, you can adjust as follows:
 - **Align the parallelism between the blade and T-slot.** Before aligning perpendicularity or parallelism of the fence, you must align the parallelism between the blade and T-slot, refer to page 24, "Aligning the Table T-slot Parallel with the Blade".

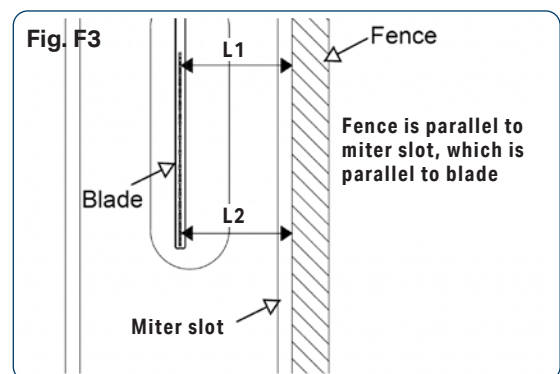
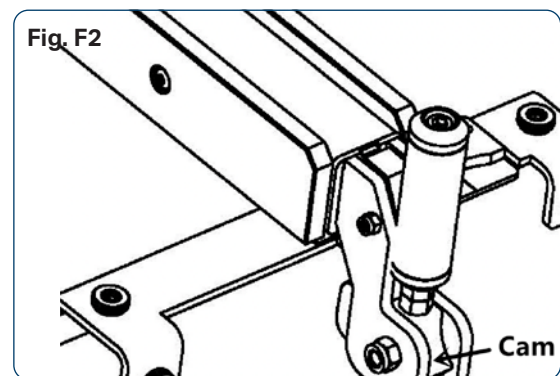
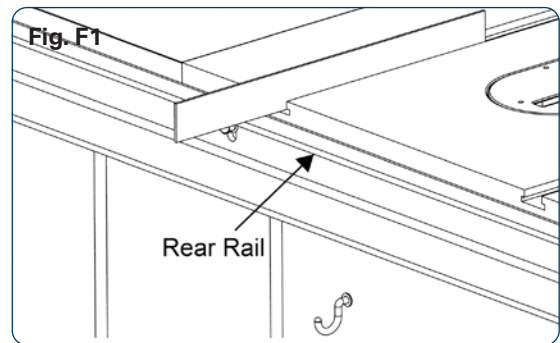

ASSEMBLY

- **Align the the parallelism between the fence and T-slot or blade. Fig. F4**

By adjusting the set screw (A), you can adjust the parallelism between the fence and the blade, and you can adjust the locking strength. By adjusting the bolt marked in a circle, you can adjust the the perpendicularity between the fence and the table. By adjusting the set screw (B), you can adjust the sliding smoothness of the fence.

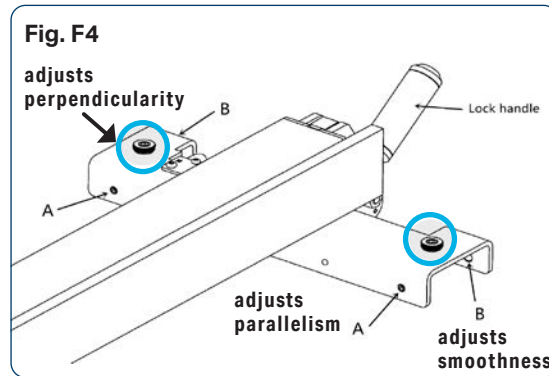

⚠ NOTICE

Note: By adjusting the support screw (not shown) at the underneath of the fence, you can raise or lower the fence to ensure that the underneath of the fence is parallel to the table.

G. POSTING THE TAPE SCALE

Fig. G1

1. Place the fence as a high fence.
2. Slide the fence against the saw blade, and lock it in place.
3. Place the front rail tape scale on the fence tube, make sure it is parallel with the tube, and the "0" end is directly under the red line on the pointer window (B),
4. Lightly mark the "0" location on the tube with a pencil.
5. Remove the fence.
6. Peel the tape.
7. Carefully align the "0" mark on the scale with the pencil mark you made.

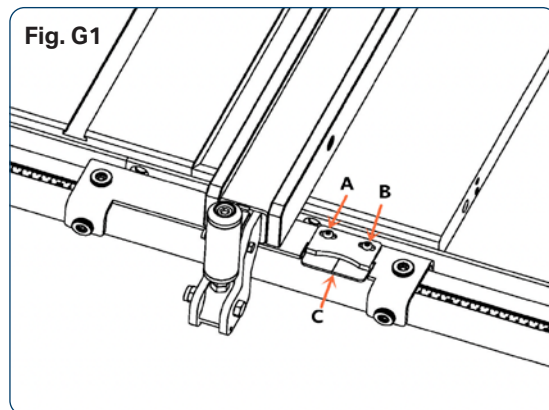

H. CALIBRATING THE POINTER WINDOW

1. Slide the fence against the blade.
2. Check the "0" mark is directly under the red line on the pointer window (C). If any deviation occurs, loosen the screws (A&B), micro-adjust the window, so that the red line on the window is over the "0" mark on the tape
3. Secure the screws (A&B).

ASSEMBLY

I. INSTALLING THE SWITCH

The switch is mounted on the lower right side of the guide tube by using two sets of bolts which are re-installed on the guide tube.

Fig. H1

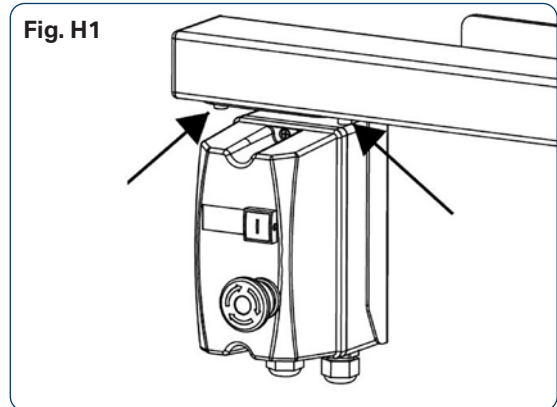

J. INSTALLING THE BLADE

1. Remove the table insert.
2. Rise the arbor all the way up and set the blade angle at 0°.
3. Remove the arbor nut and arbor flange from the arbor, slide the saw blade onto the arbor, making sure the teeth face the front of the saw, then install the arbor flange and arbor nut onto the blade.
4. Press the arbor lock pin, and use the included
5. wrench to tighten the arbor nut.

Fig. J1.

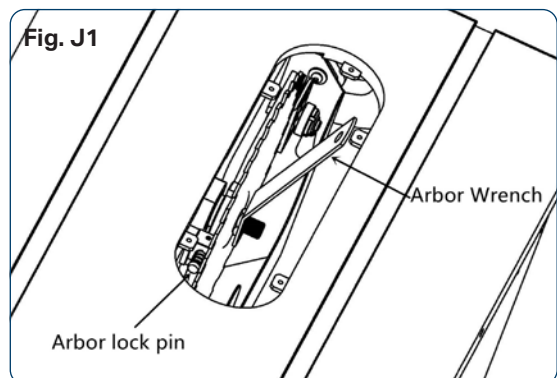

K. INSTALLING THE BLADE GUARD

1. Remove the table insert.
2. Unlock the handle. **Fig. K1**
3. Slide the blade guard spreader all the way down into the block, then lock the handle.
4. Slide the blade guard onto the spreader, tighten the lock knob. **Fig. K2**

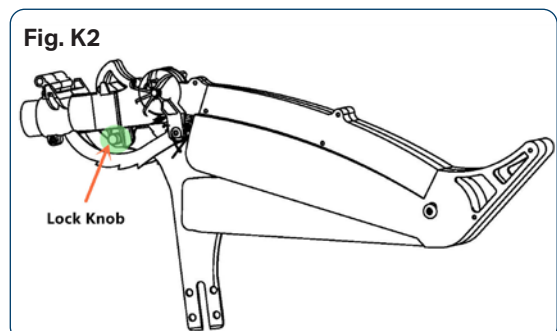
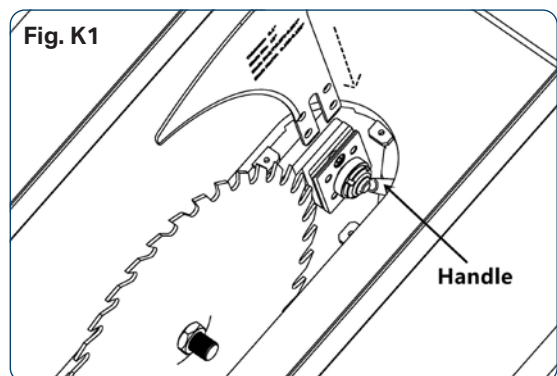

WARNING

Check if the saw blade is tightened before operating the machine. Give the spreader an upward tug to verify if it is locked in place.

ASSEMBLY

L. INSTALLING A DUST COLLECTION SYSTEM

A dust collection device should be used and switched on before commencing machining.

1. Secure the dust outlet to the cabinet, and then connect the bellows to the dust outlet
Fig. L1 & L2

Note: The mounting hardware of the dust outlet is pre-mounted on the cabinet.

2. Fit the over arm to the rear rail. **Fig. L3**
 - Fit the bracket (A) to the rear rail with screw (B).
 - Fit the over arm to the bracket (B) with clip (C). Total 2 sets of clasps.
 - Connect the pipe (1.5") provided by us to the dust outlet as fig point.
3. Requirements for the dust collector:
 - Required air flow: 470 CFM (800 m³/h).
 - Ensure pressure drop of each dust collector outlet carrying air current speed: 1100Pa
 - Dry chips: 3937 FPM (20 m/s).
 - Wet chips: 5511 FPM (28 m/s). (Water content is equal to 18%).

M. INSTALLING THE MOTOR COVER

Install the motor cover by inserting the door pins into the hinge sockets on the cabinet.

Fig. M1

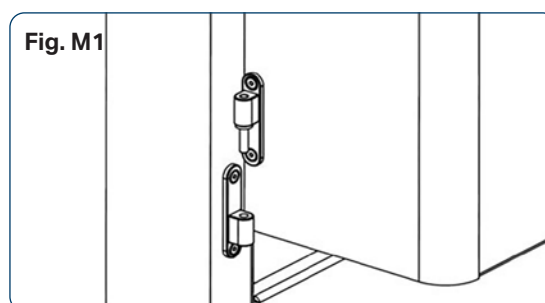
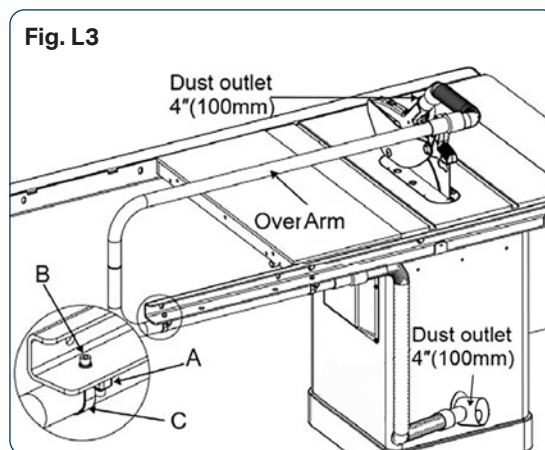
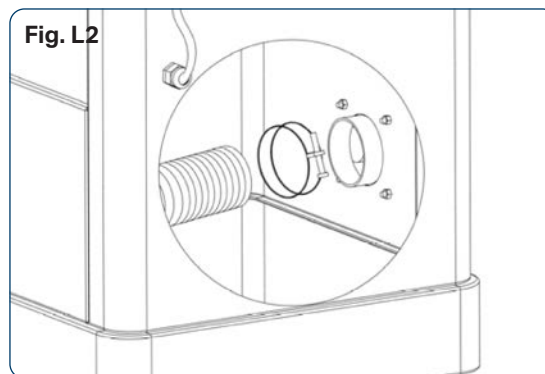
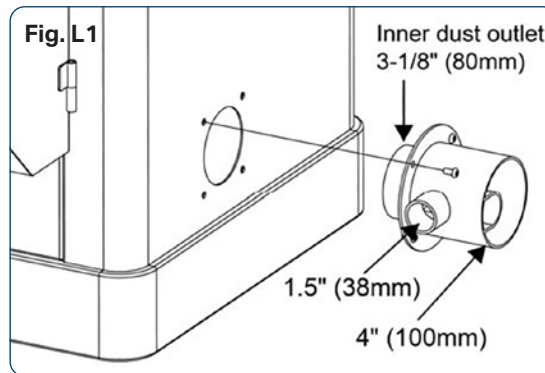

ADJUSTMENTS

N. ADJUSTING THE RIP FENCE

Before using the rip fence, the parallelism and perpendicularity must be aligned correctly. Please refer to chapter F, page 20, 'Rail and extension table installation.

O. ALIGNING THE TABLE T-SLOT PARALLEL WITH THE BLADE

The table T-slot must be aligned parallel with the blade. Using a combination square, measure the distance from the back edge of the blade to the table T-slot. Pivot blade forward 180° and re-measure the distance using the exact same point on the blade. The difference between both measurements must be less than 0.2 mm. **Fig. O1**

If an adjustment is necessary, loosen the two M5-8x8 set screws (A) and four M10-1.75x25 cap screws (B) which mount the table to the cabinet. Make the needed adjustment until both measurements are equal or less than 0.2 mm. Then re-tighten all the screws. **Fig. O2**

P. ADJUSTING THE 45° AND 90° POSITIVE STOPS

The tilt mechanism has adjustable stops for 45° and 90°. The machine comes factory-set, but should any positioning deviation of the blade occur, you can re-adjust the stops.

Fig. P1

To adjust the 45° Positive Stop:

1. Open the motor cover on the **left side** of the machine.
2. Loosen the set screw (A) and rotate the 45° Positive Stop to desired position.
3. Re-tighten the set screw. (A)

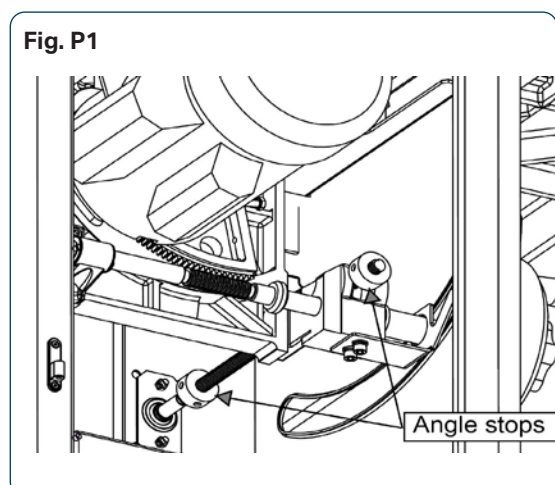
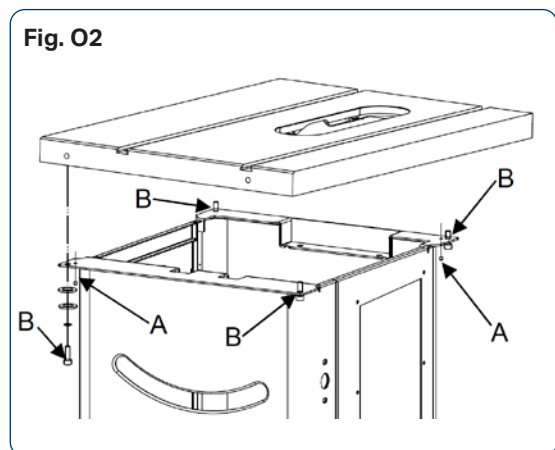
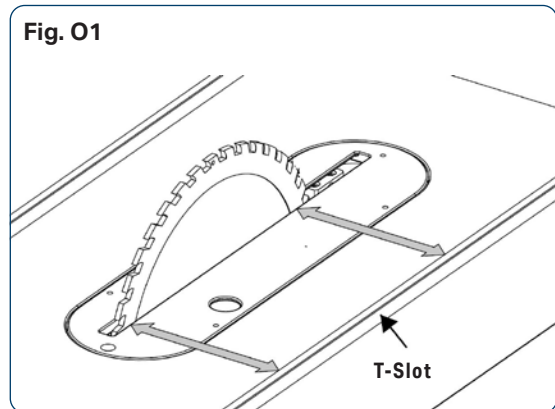

ADJUSTMENTS

To adjust the 90° Positive Stop:

1. Loosen the screws of the repair panel on the **right side** of the machine and take off the repair panel.
2. Loosen the set screw (B) and rotate the 90° Positive Stop to desired position.
3. Re-tighten the set screw (B) after adjustment.

Q. ALIGNING THE RIVING KNIFE WITH THE BLADE

The riving knife must be aligned with the blade. If not properly aligned, the riving knife will force the workpiece sideways during the cut, increasing the risk of kickback. Place a straightedge against the blade and the riving knife and check if the riving knife is in the "alignment zone." **Fig. Q1**

If not aligned properly, please adjust as follows:

Fig. Q2

1. Disconnect the saw from the power source.
2. Remove the table insert.
3. Adjust the set screws (A) in or out until the alignment is perfectly parallel.
4. Re-install the table insert.

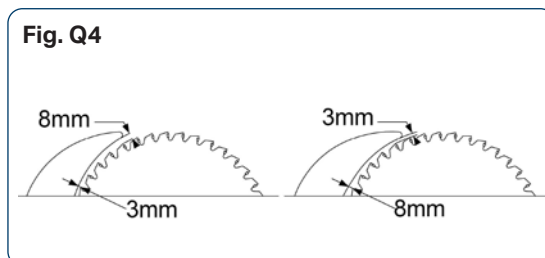
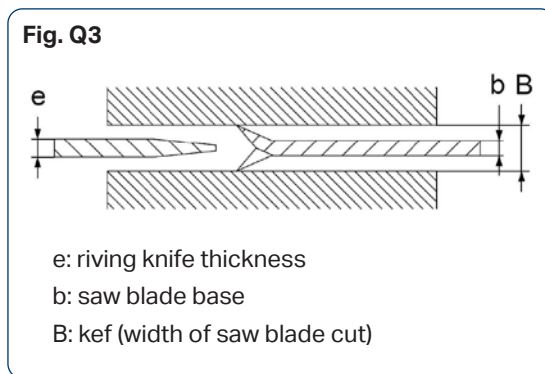
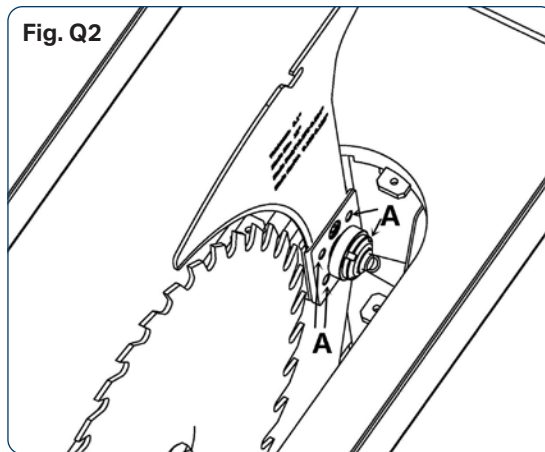
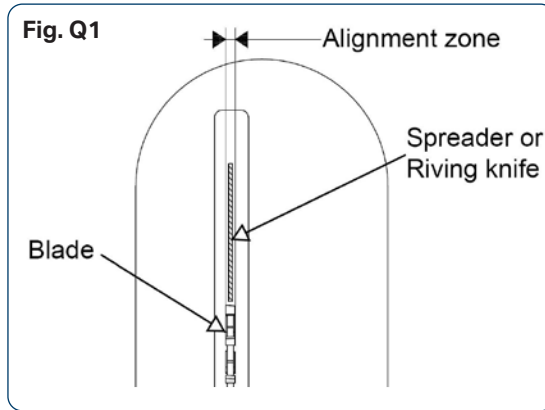



Riving knives shall be manufactured from steel with an ultimate tensile strength of 580 N/mm² or of a comparable material, have flat sides (within 0.1 mm per 100 mm) and shall have a thickness less than the width of a cut (kerf) and at least 0.2 mm greater than the saw blade plate. Fig. Q3

The distance of the riving knife from the gear rim must be between 3 mm and 8 mm measured radially through the center of the saw spindle. Fig. Q4

The highest point of the riving knife must be set beneath the topmost teeth.

OPERATION

R. ELECTRICAL OPERATION

- **"ON" Button:** Start the machine.
- **"OFF" Button:** Stop the machine.
- **Hole for Safety Lock:** While not using the machine, insert the safety pin to prevent accidental start up. **Fig. R1**

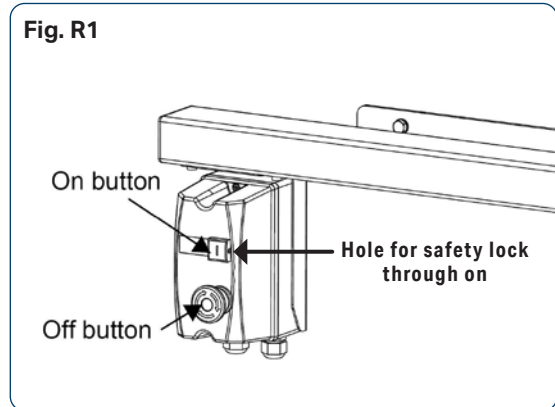

S. BLADE ELEVATION AND TILTING ADJUSTMENT

To adjust the blade elevation:

Loosen the lock knob (C) and turn the elevation hand wheel (D). When the desired height is obtained, re-tighten the knob (C). The blade should be raised 1/8" to 1/4" above the top surface of the material being cut.

Fig. S1

To adjust the blade tilting:

Loosen the lock knob (B) and turn the hand wheel (A). When the desired angle is obtained, re-tighten the knob (B).

Fig. S1

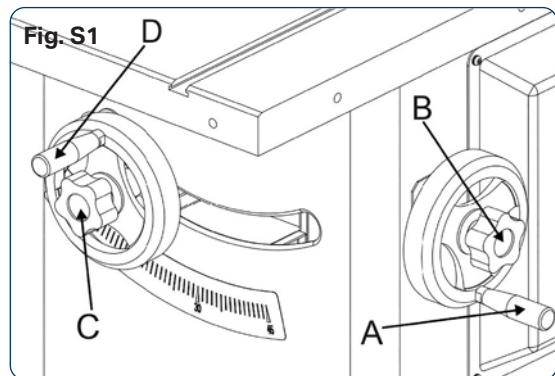

OPERATION

T. CROSSCUTTING

“Crosscutting” means **cutting across the grain** of a natural wood workpiece. In other man-made materials, such as MDF or plywood, crosscutting means **cutting across the width** of the workpiece. Crosscutting requires the use of the **miter gauge** to position and guide the work.

1. Place the work against the miter gauge and advance both the miter gauge and work toward the saw blade.
2. Start the cut slowly and hold the work firmly against the miter gauge and the table.
3. Never hang onto or touch a free piece of work. Hold the supported piece, not the free piece that is cut off.
4. The feed in crosscutting continues until the work is cut in two, then the miter gauge and work are pulled back to the starting point.
5. Before pulling the work back, give the work a little sideways shift to move the work slightly away from the saw blade.

Never pick up any short length of free work from the table while the saw is running. Never touch a cut-off piece unless it is at least a foot long. Never use the fence as a cut-off gauge when crosscutting. Never use the miter gauge in combination with the rip fence.

U. RIPPING

“Ripping” means **cutting with the grain** of a natural wood workpiece. In other man-made materials such as MDF or plywood, ripping simply means **cutting lengthwise**. Ripping requires the use of the **rip fence** to position and guide the work.

One edge of the work rides against the rip fence while the flat side of the board rests on the table. Since the work is pushed along the fence, it must have a straight edge and make solid contact with the table. The **saw guard** must be used. The guard has a splitter to prevent the saw kerf from closing.

1. Start the motor and advance the work holding it down and against the fence. Never stand in the line of the saw cut when ripping.
2. Hold the work with both hands and push it along the fence and into the saw blade.
3. Alternately, the feed can continue to the end of the table, after which the work is lifted and brought back along the outside edge of the fence.
4. The waste stock remains on the table and is not touched with the hands until the saw is stopped unless it is a large piece allowing safe removal.

MAINTENANCE

V. MAINTENANCE

This table saw has TEFC motor and sealed lubricated bearings, which requires very little maintenance other than minor lubrication and cleaning. Please do the maintenance as follows:

Lubrication, once a month.

Clean off the wood chips on the worm gears and trunnions and apply the grease to keep them lubricated.

Cleaning, when machine has been used.

Clean the wood chips on the table surface and in the cabinet.

Changing belt.



WARNING

Make sure the power cord is disconnected from the power source!

1. Lower the blade completely, then open the motor cover (right side), remove the repair panel (left side). **Fig. V1**
2. Loosen the hex bolt that secures the motor and raise the motor fully to remove tension on the V-Ribbed belt. Roll the V-Ribbed belt off.
3. Raise the motor and install a new V-Ribbed belt onto the pulleys, lower the motor to tension the V-Ribbed belt, then tighten the hex bolt.
4. Close the motor cover and repair panel.

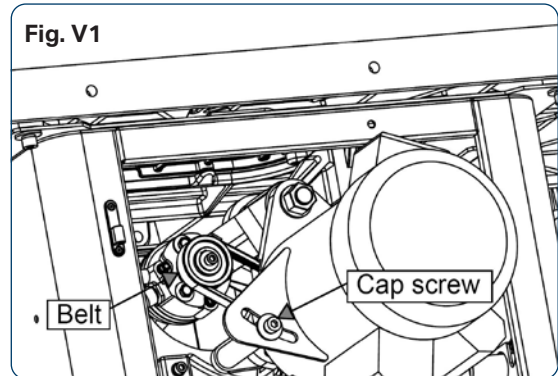

TROUBLESHOOTING

TO PREVENT INJURY TO YOURSELF or damage to the machine, turn the switch to the **"OFF"** position and unplug the power cord from the electrical receptacle before making any adjustments.

PROBLEM	LIKELY CAUSE(S)	SOLUTION(S)
Saw will not start.	<ol style="list-style-type: none"> 1. Saw not plugged in. 2. Fuse blown or circuit breaker tripped. 3. Cord damaged. 	<ol style="list-style-type: none"> 1. Plug in saw. 2. Replace fuse or reset circuit breaker. 3. Have cord replaced by a certified electrician.
Overload kicks out frequently.	<ol style="list-style-type: none"> 1. Extension cord too long or gauge size too small. 2. Feeding stock too fast. 3. Blade in poor condition (dull, warped, gummed) 4. Blade binding due to misaligned rip fence. 5. Blade binding due to warped wood. 6. Low house current. 	<ol style="list-style-type: none"> 1. Change speed. 2. Feed stock more slowly. 3. Clean or replace blade. 4. Check and adjust the rip fence. Refer to rip fence instructions. 5. Select another piece of wood. 6. Contact your electrical company.
Does not make accurate 45° and 90° rip cuts.	<ol style="list-style-type: none"> 1. Positive stop(s) not adjusted properly. 2. Tilt angle pointer not set properly. 	<ol style="list-style-type: none"> 1. Check blade with square and adjust positive stop. 2. Check blade with square and adjust pointer to zero.
Material pinches blade when ripping.	<ol style="list-style-type: none"> 1. Rip fence not aligned with blade. 2. Warped wood. 	<ol style="list-style-type: none"> 1. Check and adjust rip fence. 2. Select another piece of wood.
Material binds on splitter.	<ol style="list-style-type: none"> 1. Splitter not aligned correctly with blade. 	<ol style="list-style-type: none"> 1. Check and align splitter with blade.
Saw makes unsatisfactory cuts.	<ol style="list-style-type: none"> 1. Dull blade. 2. Blade mounted backwards. 3. Gum or pitch on blade. 4. Incorrect blade for work being done. 5. Gum or pitch on table causing erratic feed. 	<ol style="list-style-type: none"> 1. Replace blade. 2. Turn blade around. 3. Remove blade and clean with turpentine and steel wool. 4. Change the blade. 5. Clean the table with turpentine and steel wool.
Blade does not come up to speed.	<ol style="list-style-type: none"> 1. Extension cord too light or too long. 2. Low house current. 3. Motor not wired for correct voltage. 3. Refer to motor and /or nameplate. 	<ol style="list-style-type: none"> 1. Replace with adequate size extension cord. 2. Contact your electric company. 3. Refer to motor and /or nameplate.
Machine vibrates excessively.	<ol style="list-style-type: none"> 1. Table not mounted securely to cabinet stand. 2. Stand is on uneven floor. 3. Damaged saw blade. 4. Bad V-Ribbed belt. 5. V-Ribbed belt is not tensioned properly. 6. Improper motor mounting. 7. Loose hardware. 	<ol style="list-style-type: none"> 1. Tighten all mounting hardware. 2. Reposition on flat level surface. 3. Replace blade. 4. Replace V-Ribbed belt. 5. Adjust V-Ribbed belt tension. 6. Check and adjust motor mounting. 7. Tighten all nuts, bolts and set screws.

HIGH CONFIGURATION OF MECHANICAL PARTS

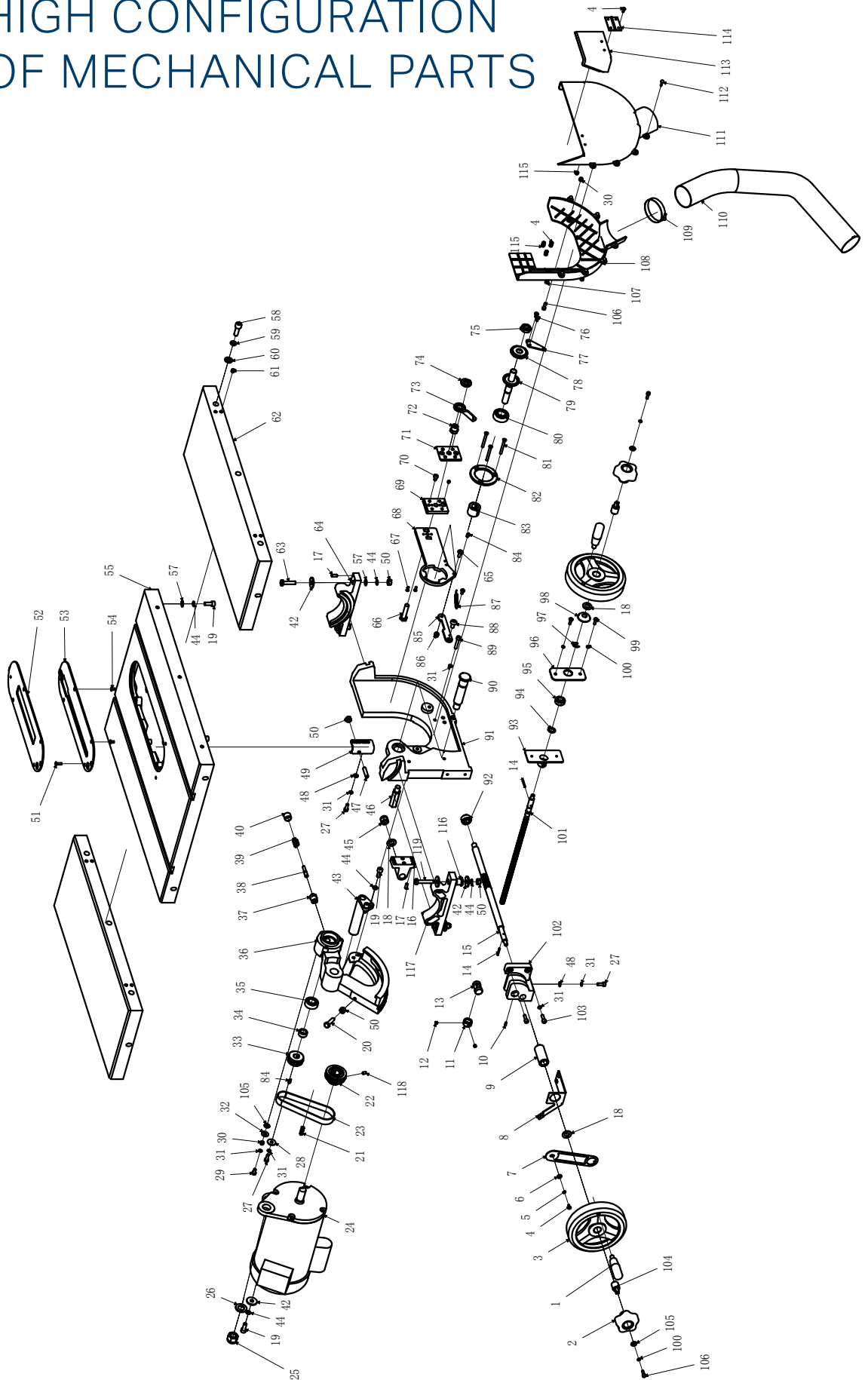

HIGH CONFIGURATION OF MECHANICAL PARTS

1	Turn HandleM10*100	2	40	Block Shot	1	81	Flat head Screw M5*50	3
2	Handle	2	42	Flat Washer $\phi 8*28*3$	7	82	Gland	1
3	HandleWheel	2	43	Vonnecting Shaft	1	83	Brake Sleeve	1
4	Button Head Screw M4*10	5	44	Lock Washer $\phi 8$	11	84	Key A5*12	2
5	Lock Washer $\phi 4$	1	45	Lock Nut M12	1	85	Connecting Rod	1
6	Flat Screw $\phi 4$	1	46	Limit Post	1	86	Lock Nut M6	1
7	Pointer Plate	1	47	Set Screw M8*35	1	87	Drag Spring	1
8	Fixed Plate	1	48	Flat Washer $\phi 6$	4	88	Button Head Screw M8*16	1
9	Locking Ring	1	49	Stop Plate	1	89	Cap Screw M6*35	2
10	Set Screw M4*10	1	50	Hex Nut M8	6	90	Fixed Shaft	1
11	Locating Ring	2	51	HSC-Head Screw M5*16	1	91	Main Turnnion	1
12	Set Screw M6*6	10	52	Tenoned Cover Plate	1	92	Locating Sleeve	1
13	Silk Nut	1	53	Standard Cover Plate	1	93	Splint One	1
14	Tension Pin3*25	2	54	HSC-Head Screw M5*10	4	94	Adjusting Pad	1
15	Lifting Shaft	1	55	Worktable	1	95	Bearing	1
16	Fixed Block	1	57	Flat Washer $\Phi 8$	6	96	Splint Two	1
17	Set Screw M6*16	8	58	Cap Screw M10*35	6	97	E-Clip $\phi 9$	1
18	Spacer 13-24-2	3	59	Lock Washer $\phi 10$	6	98	Cardan Sleeve	1
19	Cap Screw M8 *20	7	60	Flat Washer $\phi 10$	6	99	Button Head Screw M5*16	2
20	Hex Bolt M8 x*30	1	61	Set Screw M8*8	8	100	Lock Washer $\phi 5$	4
21	Key 6*25	1	62	Extesionn Wing	2	101	Screw	1
22	Motor Wheel	1	63	Hex Bolt M8*35	2	102	Fixed Base	1
23	P-Zone 150J	1	64	Template	1	103	Cap Screw M6*20	2
24	Motor	1	65	PH Head Screw M6*16	1	104	Handle Sleeve	2
25	Lock Nut M16	1	66	Hex Bolt M10*45 Left	1	105	ENLARGE Washer 5	5
26	Washer $\phi 16$	1	67	HSC-Head Screw M4*12	2	106	Cap Screw M5*16	4
27	Cap Screw M6*16	5	68	Follower Plate	1	107	Cap Screw M5*25	1
28	Flat Washer $\phi 6*25*2$	1	69	Fixed Plate	1	108	Shield A	1
29	Hex Bolt M6*12	3	70	Cap Screw M6*8	2	109	Locking Ring70-90	1
30	Lock Nut M5	6	71	Locking Plate	1	110	Vacuum Tube80	1
31	Lock Washer $\phi 6$	12	72	Lock Nut	1	111	Shield B	1
32	Flat Washer $\phi 6*20*2.5$	3	73	Locking Handle	1	112	Tap Screw 3.5*16	6
33	Saw Shaft Wheel	1	74	Round Nut M16*1.5	1	113	Shield C	1
34	Spacer	1	75	Hex Nut M16*1.5	1	114	Hinge	1
35	Bearing 6202	1	76	Button Head Screw M5*10	3	115	Lock Nut M4	4
36	Saw Shaft Sleeve	1	77	Connecting Plate	1	116	Adjust Screw	2
37	Brake Pin Block	1	78	Gland	1	117	Template Left	1
38	Brake Pin	1	79	Saw Shaft	1	118	Set Screw M6*10	2
39	spring		80	Bearing 62031		119	Hex Bolt M8*45	2

HIGH CONFIGURATION BOX

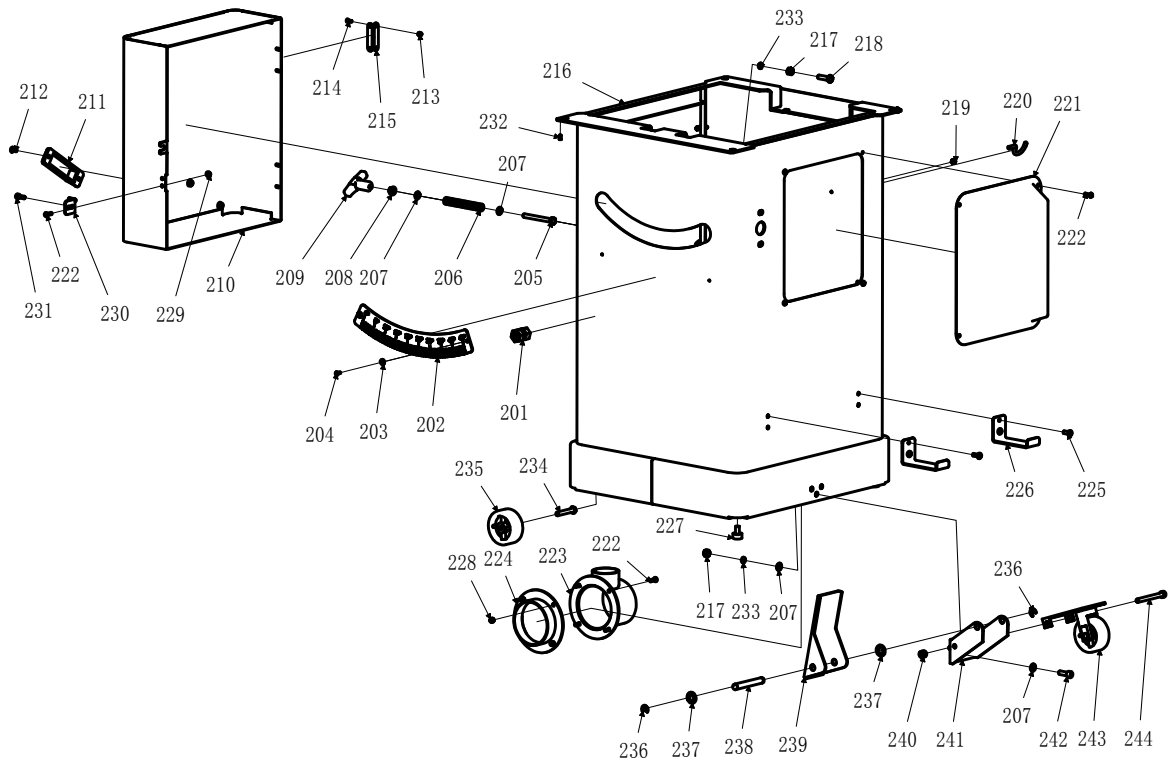

32

201	Strain Relief	1	223	Dust Suction Port (100)	1
202	Angle Ruler	1	224	Dust Suction Port (80)	1
203	Enlarge Washer $\phi 4$	2	225	Button Head Screw M6*16	4
204	Button Head Screw M4*10	2	226	Bracket	2
205	Hex Bolt M8*80	1	227	Door Mat M8*16	2
206	Compression Spring	1	228	Lock Nut M5	4
207	Plate Washer $\phi 8$	8	229	Lock Nut M5	2
208	Hex Nut M8	1	230	Plate	1
209	T-Handle	1	231	Cap Screw M6*16	1
210	Motor Shield	1	232	Set Screw M5*10	2
211	Place The Support	1	233	Lock Washer 8	7
212	Flat Head Screw M6*12	2	234	Hex Bolt M8*50	2
213	Lock Nut M4	8	235	WHEEL	2
214	Plate Head Screw M4*12	8	236	E-Clip 9	2
215	Hinge	2	237	Flat Washer 12	2
216	Sheet Metal Box	1	238	SHAFT 12	1
217	Hex Nut M8	7	239	PEDAL	1
218	Hex Bolt M8*30	4	240	Lock Nut M8	1
219	Hex Nut M5	2	241	PEDAL BRACKET	1
220	Hook	2	242	Cap Screw M8*25	3
221	Baffle	1	243	TROLLEY UNIVERSAL KIT	1
222	Button Head Screw M5*16	10	244	Cap Screw M8*100	1

WORKTABLE AND GUIDE RAIL

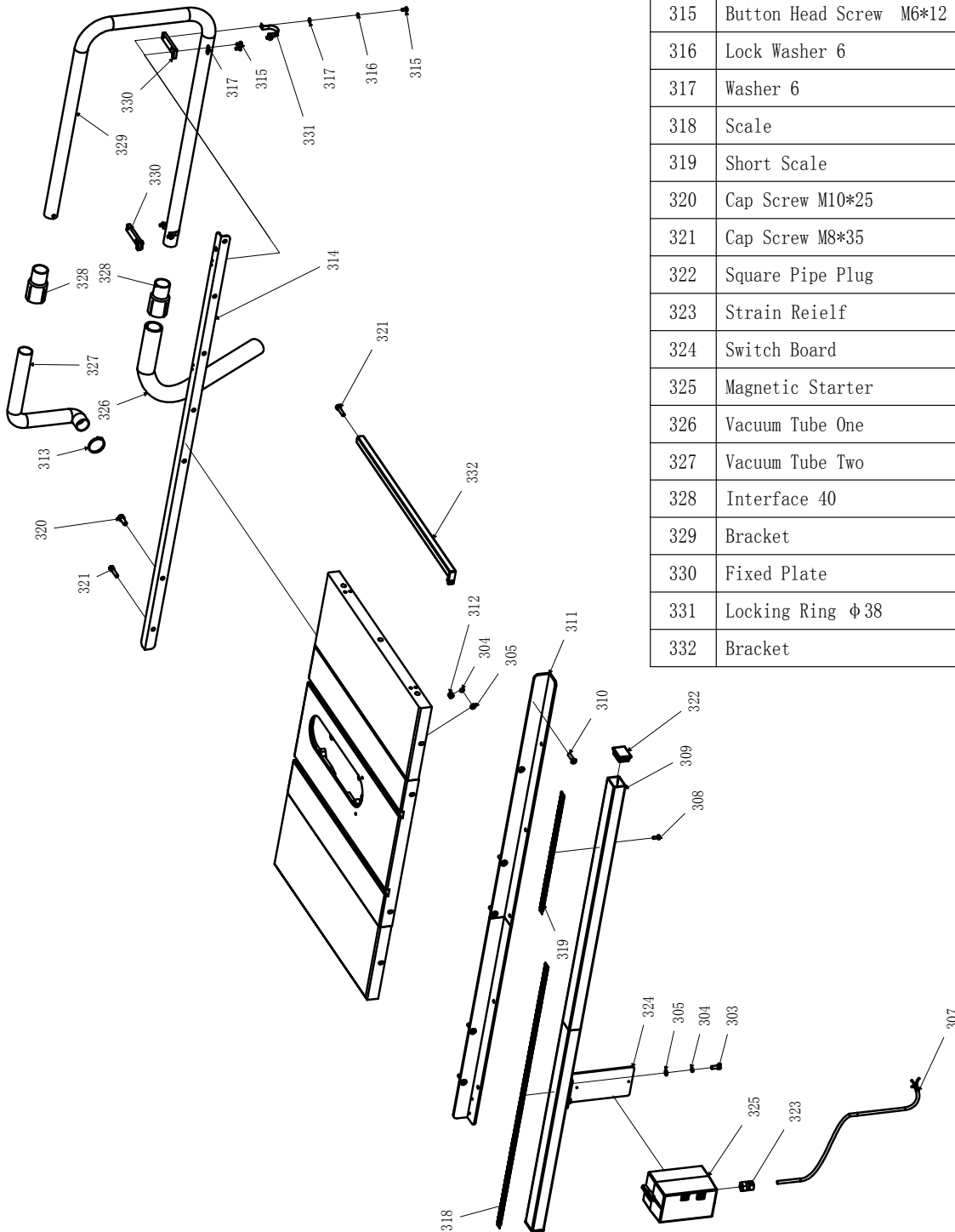

303	Hex Bolt M8*20	2
304	Lock Washer 8	10
305	Washer 8	10
307	Wire	1
308	Button Head Screw M6*16	5
309	Square Tube	1
310	Flat Head Screw M8*35	5
311	F-Angle Iron	1
312	Nut M8	7
313	Locking Ring	2
314	B-Angle Iron	1
315	Button Head Screw M6*12	8
316	Lock Washer 6	4
317	Washer 6	8
318	Scale	1
319	Short Scale	1
320	Cap Screw M10*25	2
321	Cap Screw M8*35	3
322	Square Pipe Plug	2
323	Strain Reieif	1
324	Switch Board	1
325	Magnetic Starter	1
326	Vacuum Tube One	1
327	Vacuum Tube Two	1
328	Interface 40	2
329	Bracket	1
330	Fixed Plate	2
331	Locking Ring ϕ 38	2
332	Bracket	1

BACKING PART OF HIGH C-STEEL PIPE

701	Button Head Screw M6*20	6
702	Backboard	2
703	Transverse Connecting Plate	1
704	Square Stopper	2
705	Rivet	2
706	Screw $\phi 8.2-\phi 16-1.5$	2
707	Locking Block	1
708	Cam Block	1
709	Nut M10	2
710	Front Sleeve	1
711	Intermediate Sleeve	1
712	Back Sleeve	1
713	Cap Screw M10*130	1
714	Hex Bolt M10*50	1
715	Hex Bolt M6*45	1
716	Button Head Screw M6*10	2
717	Pointer	1
718	Pipe Plug	1
719	Lock Nut M6	7
720	Pulling Nut M12	1
721	Long Adjusting Thread	1
722	Set Screw M8*8	2
723	Support Assembly	1
724	Lock Nut M10	1
725	Short Adjusting Thread	4
726	Compound Nut M12	5
727	Tension PIN 4*32	1
728	Compression Spring	1

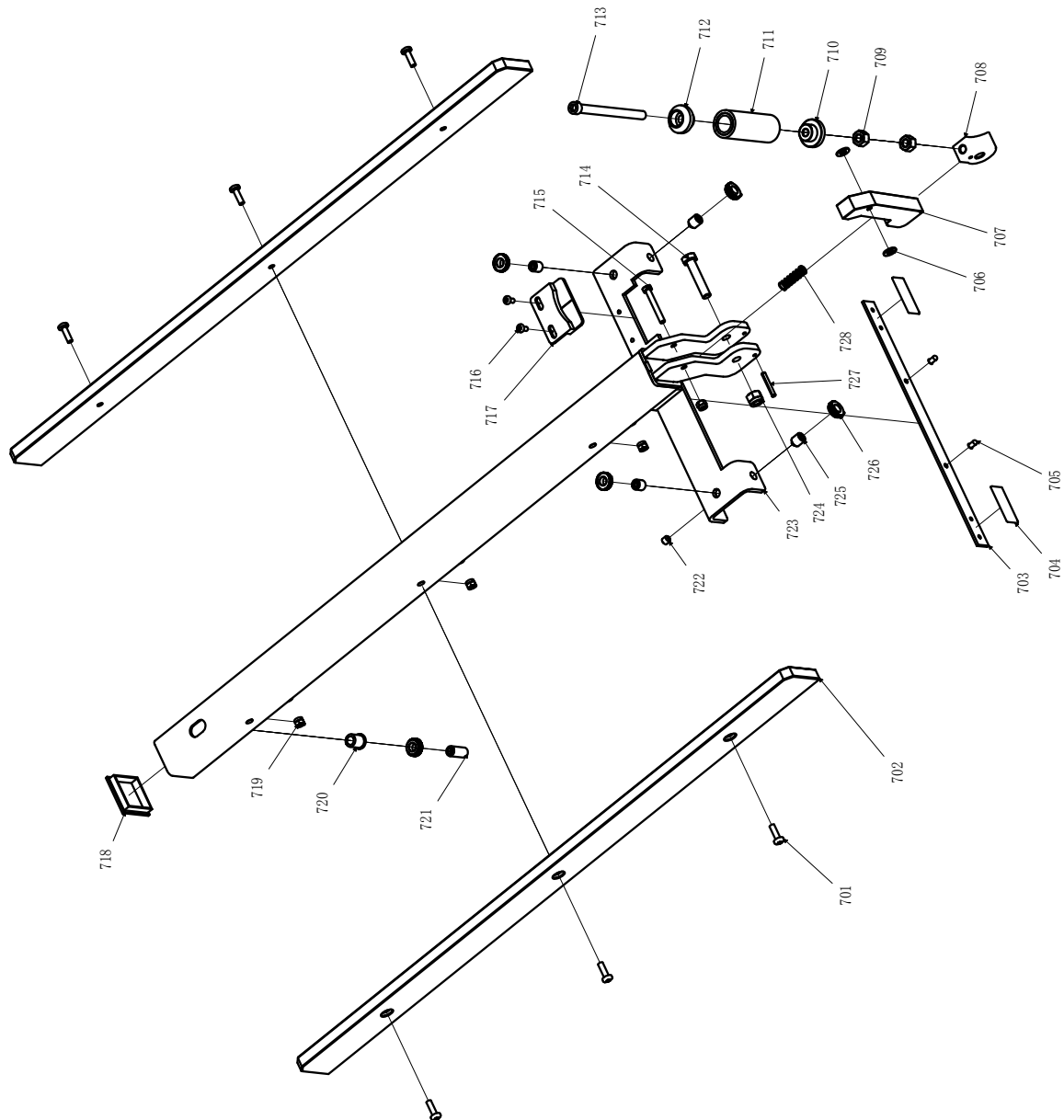

MITER GAUGE WITH STOP DEVICE

501	P-Head Screw M6-8	1
502	T-Solt Washer	1
503	Miter Bar	1
504	Washer $\phi 15-\phi 5-4$	4
505	Flat Head Screw M5*8	4
506	Locating Plate	1
507	Flat Washer $\phi 5$	4
508	Button Head Screw M5*8	5
509	Washer $\phi 6-\phi 12-5$	2
510	Plug Screw	2
511	Set Screw M6*20	1
512	Hex Nut M6	1
513	Locking Front Sleeve	1
514	Set Screw M6*6	1
515	Locking Drip	1
516	Locking Rear Sleeve	1
517	Cap Screw M10*85	1
518	Washer $\phi 6-\phi 20-1$	1
519	Angle Ruler Plate	1
520	Angle Ruler Base	1
521	Button Head Screw M4*8	1
522	Lock Washer $\phi 4$	1
523	Stop Plate	1
524	Torsion Spring	1
525	Flat Washer $\phi 6$	2
526	Combination Nut M6	2
527	Set Screw M6*6	2
528	Hex Bolt M6*16	2
529	L-Aluminum Baffle	1
530	Nut M6	1
531	Lock Nut M6	1
532	Screw $\phi 8.2-\phi 16-1.5$	2
533	Stop Plate	1
534	Fixed Shaft	1
535	Fixed Block	1
536	Locking Handle M6*30	1

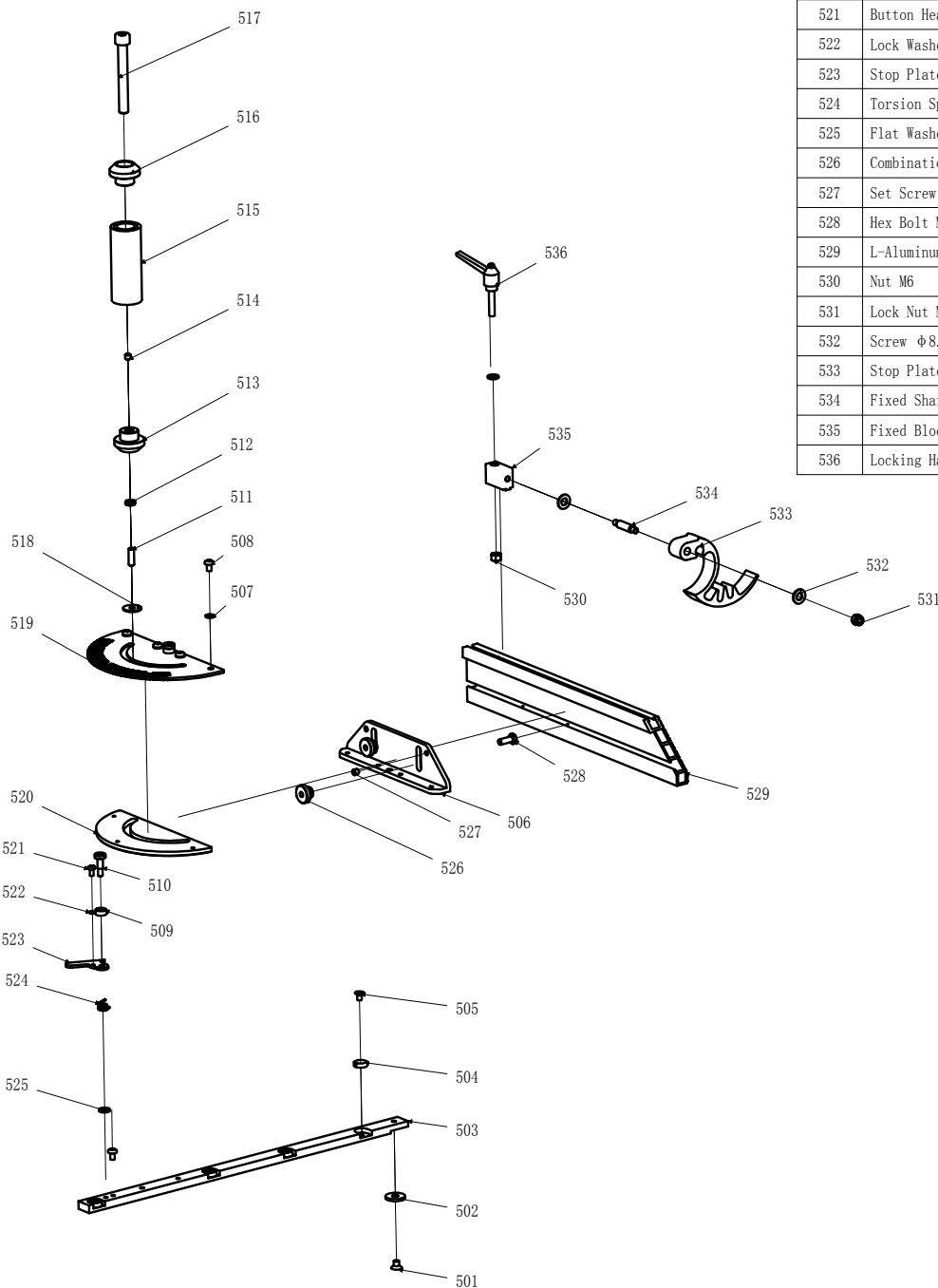

PROTECTIVE COVER

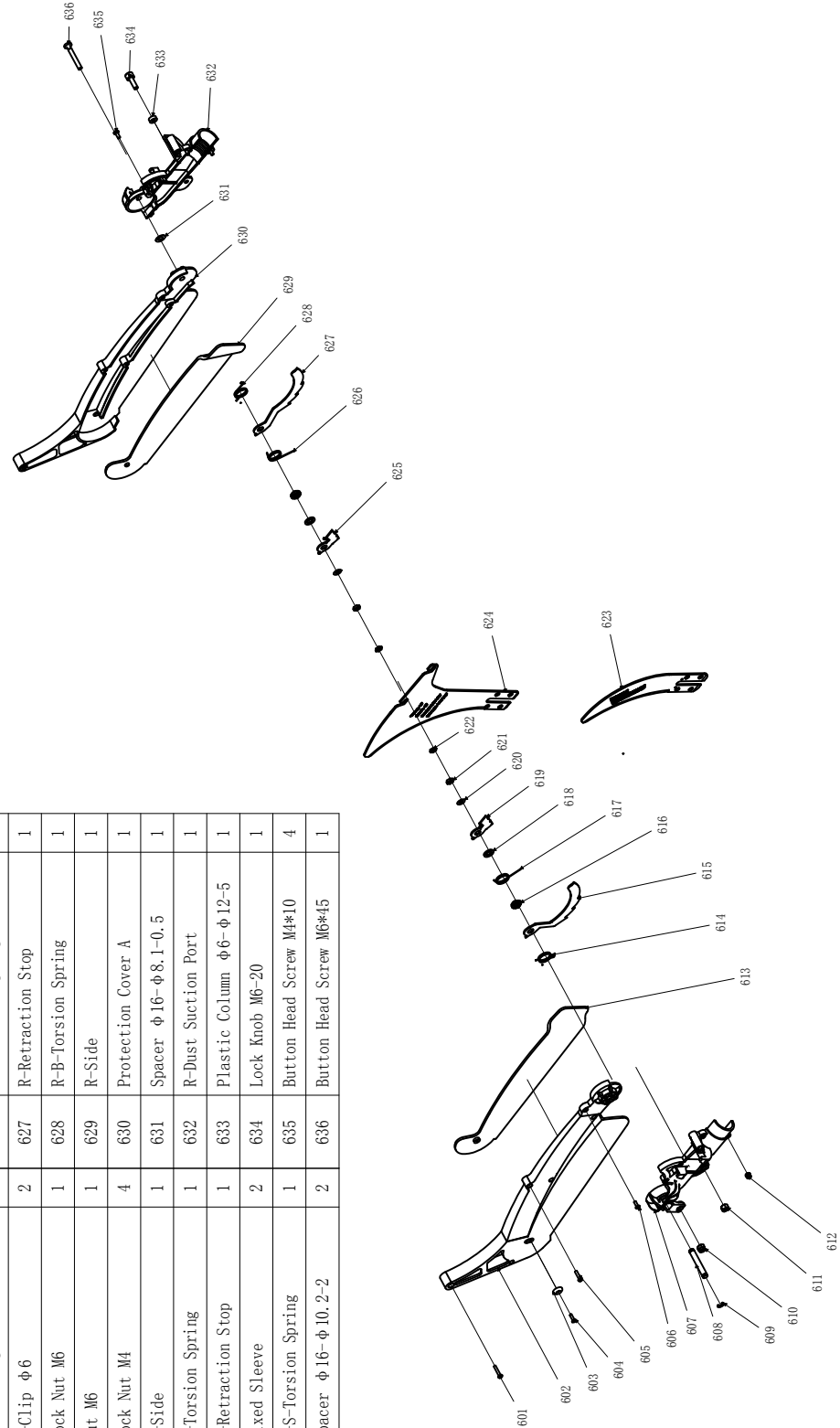

601	P-Head Self Tapping 3.5*20	2	619	L-S-Retraction Stop	1
602	Protection B	1	620	S-Steel Gasket $\phi 6$	2
603	Plug	2	621	Thin Nut M6	2
604	C-Head Self Tapping 3.5*12	2	622	U-Thin Nut M6	2
605	P-Head Self Tapping 3.5*16	2	623	Dividing Knife	1
606	P-Head Self Tapping 3.5*10	2	624	Cleaver Plate	1
607	L-Dust Suction Port	1	625	R-S-Stop Plate	1
608	Positioning Axis	1	626	L-S-Torsion Spring	1
609	E-Clip $\phi 6$	2	627	R-Retraction Stop	1
610	Lock Nut M6	1	628	R-B-Torsion Spring	1
611	Nut M6	1	629	R-Side	1
612	Lock Nut M4	4	630	Protection Cover A	1
613	L-Side	1	631	Spacer $\phi 16-\phi 8.1-0.5$	1
614	L-Torsion Spring	1	632	R-Dust Suction Port	1
615	L-Retraction Stop	1	633	Plastic Column $\phi 6-\phi 12-5$	1
616	Fixed Sleeve	2	634	Lock Knob M6-20	1
617	R-S-Torsion Spring	1	635	Button Head Screw M4*10	4
618	Spacer $\phi 16-\phi 10.2-2$	2	636	Button Head Screw M6*15	1

WIRING DIAGRAM

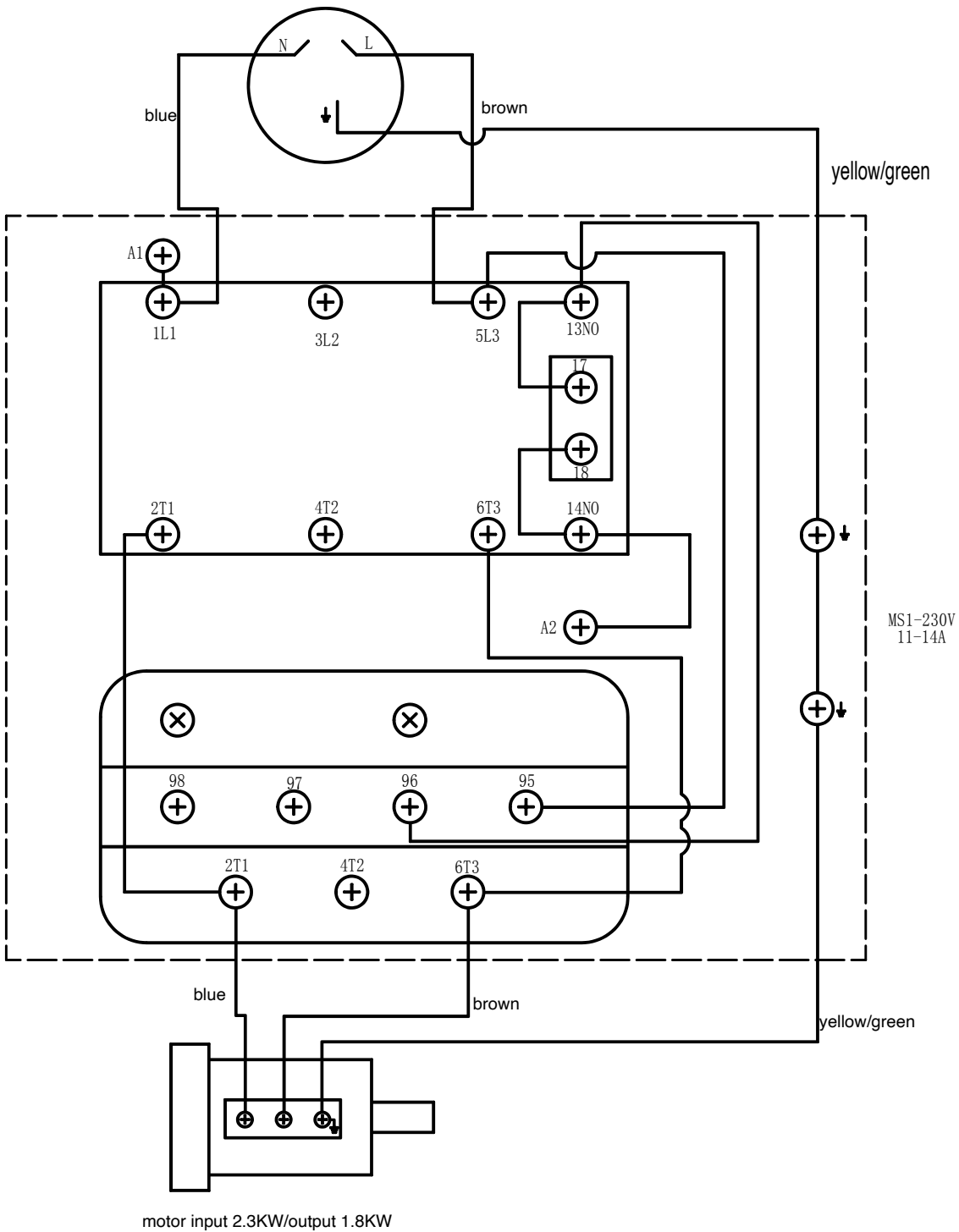

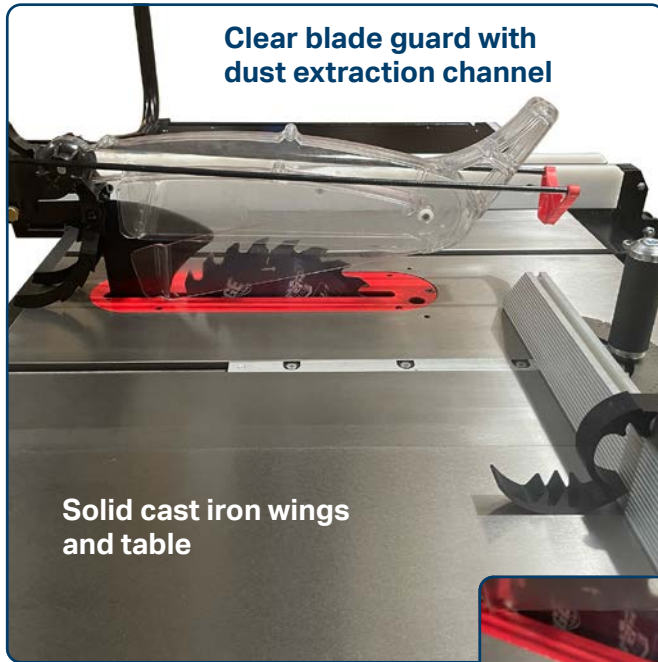

Premium miter gauge with 5° increment stops



2 YEAR WARRANTY

WARRANTY

- A. We warrant that this Carbatec product will be free from defects caused by faulty workmanship or faulty materials for a period of 2 years from date of sale.
- B. This warranty is in addition to other rights and remedies you may have under a law in relation to the goods.
- C. This warranty does not apply in any of the following cases:
- i. Defects arising from:
 1. fair wear and tear;
 2. corrosive atmosphere;
 3. damage or injury caused by deliberate act, lack of care or failure to comply with the recommended care and maintenance for the goods;
 4. improper use of the goods;
 5. alterations or repairs (not made by us) to the goods;
 - ii. defects arising from an event outside of our control such as fire, flood, earthquake or other natural calamity, motor vehicle or other accident, strike, civil unrest, terrorism or war;
 - iii. to accessory items such as after-market jigs, accessories or other items which are not sold or serviced by us and which are not sold with or were not included with the main unit purchased; or
 - iv. to wearable parts such as drive belts/shafts, bearings, bandsaw tyres, motor brushes, blades or abrasive belts/discs or other cutting or machining implements.
 - v. damage caused to any electrical component, where connected to a power supply outside the country for which it was designed (namely Australia or New Zealand).
- D. If this warranty applies and you have complied with the procedure below for making a claim, we will, at our election, either repair the goods (or those parts of the goods recognised as defective) or will provide a replacement within a reasonable time at our expense.
- E. If this warranty applies, the procedure for making a claim is:
- i. you must contact us by email;
 - ii. you must include in the email the following information:
 1. a copy of the order or receipt for the goods;
 2. the serial or batch number printed on the machinery manufacturing plate; and
 3. a detailed description of the fault and how and when it arose; and
 4. If the fault is a type covered by this warranty, we will then make arrangements with you for the return of the goods to us (for repair or replacement) at our cost using our transport providers or we may decide to attend at your premises to repair or replace the goods.
- F. Our liability (and that of our resellers) under this warranty is wholly limited to repair or replacement of the goods (or those parts of the goods recognised as defective) in accordance with the procedure above and you have no right to other compensation, costs or damages under this warranty. But this does not mean that you may not have other rights under a law in relation to the goods.
- G. If following our inspection of goods returned by you under this warranty it is found that this warranty does not apply and you are not otherwise entitled to repair or replacement by us, you must, if requested by us, reimburse our costs including parts, labour and freight.
- H. This warranty is not transferable and only the person who purchased the goods may make a claim.
- Where the goods have been exported outside Australia or New Zealand, the Company may not require the Purchaser to return any allegedly faulty or defective Product for evaluation. However, the Company has the right to request the return for evaluation at purchasers cost.

STATUTORY NOTICE

Our goods come with guarantees that cannot be excluded under the Australian Consumer Law. You are entitled to a replacement or refund for a major failure and for compensation for any other reasonably foreseeable loss or damage. You are also entitled to have the goods repaired or replaced if the goods fail to be of acceptable quality and the failure does not amount to a major failure.

TS-C250PX CARBATEC DELUXE 10" CABINET TABLE SAW



Carbatec Pty Ltd

E info@carbatec.com.au

AU 1800 658 111

NZ 0800 444 329

1/364 New Cleveland Rd,
QLD 4173,
Australia

ABN 84 010 706 242

carbatec.com.au

carbatec®

2 YEAR
WARRANTY