



The stand is sold separately.

WDS-4080P CARBATEC WIDE DRUM SANDER 400/800MM

INSTRUCTIONS MANUAL

carbatec.com.au

carbatec®

2 YEAR
WARRANTY

THANK YOU FOR CHOOSING carbatec®

Carbatec has been a trusted brand for woodworking enthusiasts and professionals across Australia and New Zealand, since 1987.



Our quality woodworking products are designed and built to offer value and performance, making the latest features and technological advancements more accessible to Aussie woodworkers.

Backed by our no-fuss after-sales care and warranty support, you can trust Carbatec to keep you woodworking, as promised.

We look forward to sharing in your woodworking journey!

If you have any questions about our products or service, please call us on **1800 658 111** or email us at info@carbatec.com.au

Find us on social media

-  facebook.com/Carbatec
-  instagram.com/Carbatec
-  youtube.com/@CarbatecTheHomeOfWoodworking

WHAT'S IN THE BOX

The following items are provided in the shipping box:



WIDE DRUM SANDER WDS-4080P

- A. Sander assembly
- B. Height adjustment handle
- C. Dust hose hook and screws

This wide drum sander will require a minimal amount of assembly.

1. Remove parts from all of the cartons and lay them on a clean work surface.
2. Remove any protective materials and coatings from all of the parts and from the wide drum sander. The protective coatings can be removed by spraying WD-40 on them and wiping it off with a soft cloth. This may need to be redone several times before all of the protective coatings are removed completely.
3. Compare the items above to verify that all items are accounted for before discarding the shipping box.

CAUTION

DO NOT USE ACETONE, gasoline or lacquer thinner to remove any protective coatings.

WARNING

If you cannot find an item on this list, carefully check around and inside the machine and components. Often, these items get lost in packaging materials. Remove all packing from the carton and re-check.

IMPORTANT

DUST COLLECTION: All woodworking machines require effective dust extraction to ensure quality work and longevity of the machine itself. Failure to connect your machine to a suitable dust collector may affect your warranty. The collector required for your machine will depend on several factors including the type of machine and its dust port connection, distance between collector and machine, type and frequency of use and the material being worked. We recommend a dust collector that will provide you a minimum airflow of 500-CFM when measured at the machine connection.

4

Key information can be found on the inspection panel, found on the rear of the machine.



carbatec
QUALITY INSPECTED

Model:
Voltage
Freq:
Phase:
Amp:
kW:
Speed:
Lot No.:
Serial No.:
Date:

Made in:
for CARBATEC PTY LTD
Brisbane - Australia





Record the serial number and date of purchase in your manual for future reference.

SERIAL NUMBER:

.....

DATE OF PURCHASE:

.....

CONTENTS

Introduction	2
What's in the box	3
Key information	4
Safety instructions - General	6-9
Safety instructions - Wide Drum Sander	10
Safety instructions - Electrical	11
Overview	12
Specifications	13
Introduction to drum sanding	14-15
Assembly	16-18
Machine adjustments	19-24
Operation	25
Maintenance	26
Troubleshooting	27
Wiring Diagram	28
Parts diagrams & Parts lists	28-30
Warranty	31

NOTE: The specifications, photographs, drawings and information in this manual represent the current machine model when the manual was prepared. Changes and improvements may be made at any time, with no obligation on the part of Carbatec to modify previously delivered units. Reasonable care has been taken to ensure that the information in this manual is correct, to provide you with the guidelines for the proper safety, assembly and operation of this machine.

SAFETY INSTRUCTIONS

IMPORTANT! Safety is the single most important consideration in the operation of this equipment. The following instructions must be followed at all times. Failure to follow all instructions listed below may result in electric shock, fire, and/or serious personal injury. There are certain applications for which this tool was designed. We strongly recommend that this tool not be modified and/or used for any other application other than that for which it was designed. If you have any questions about its application, do not use the tool until you have contacted us and we have advised you.

The purpose of safety symbols is to attract your attention to possible dangers. The safety symbols and the explanations with them deserve your careful attention and understanding. The symbol warnings do not, by themselves, eliminate any danger. The instructions and warnings they give are no substitutes for proper accident prevention measures.



WARNING

Be sure to read and understand all safety instructions in this manual, including all safety alert symbols such as **"DANGER," "WARNING,"** and **"CAUTION"** before using this tool. Failure to following all instructions listed below may result in electric shock, fire, and/or serious personal injury.

6

SYMBOL MEANING



A safety alert symbol Indicates **DANGER, WARNING,** or **CAUTION.** May be used in conjunction with other symbols or pictographs.



DANGER

Indicates an imminently hazardous situation, which, if not avoided, will result in death or serious injury.



WARNING

Indicates a potentially hazardous situation, which, if not avoided, could result in death or serious injury.

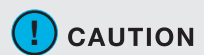

CAUTION

Indicates a potentially hazardous situation, which, if not avoided, could result in minor or moderate injury.

NOTICE

(Without Safety Alert Symbol) Indicates a situation that may result in property damage.



Carbatec products bearing the Regulatory Compliance Mark (RCM) have been tested in accordance with applicable Australian/New Zealand Standards to ensure their compliance with all mandatory standards and regulations (applicable at time of original sale). Carbatec Pty Ltd are registered as a responsible supplier with relevant Australian government departments and our products are registered on the EESS & ACMA database.

GENERAL SAFETY

Operating a power tool can be dangerous if safety and common sense are ignored. The operator must be familiar with the operation of this machine. Read this manual to understand this machine. **DO NOT operate this machine if you do not fully understand the limitations of this tool.**

DO NOT MODIFY this machine in any way.

BEFORE USING THIS MACHINE



WARNING

To avoid serious injury and damage to the tool, read and follow all of the Safety and Operating Instructions before operating the machine.



WARNING

- SOME DUST CREATED BY USING POWER TOOLS CONTAINS CHEMICALS** known to cause cancer, birth defects, or other reproductive harm. Some examples of these chemicals are:
 - Lead from lead-based paints.
 - Crystalline silica from bricks, cement, and other masonry products.
 - Arsenic and chromium from chemically treated lumber.

Your risk from these exposures varies, depending on how often you do this type of work. To reduce your exposure to these chemicals: work in a well ventilated area and work with approved safety equipment, such as those dust masks that are specially designed to filter out microscopic particles.

- READ** this entire manual. **LEARN** how to use the tool for its intended applications.
- GROUND ALL TOOLS.** If the tool is supplied with a 3-prong plug, it must be plugged into a 3-contact electrical receptacle. The third prong is used to ground the tool and provide protection against accidental electric shock.
- AVOID A DANGEROUS WORKING ENVIRONMENT.** Do not use electrical tools in a damp environment or expose them to rain.
- DO NOT USE** electrical tools in the presence of **FLAMMABLE** liquids or gases.
- ALWAYS KEEP THE AREA CLEAN,** well lit, and organized. Do not work in an environment with floor surfaces that are slippery from debris, grease, and wax.
- KEEP VISITORS AND CHILDREN AWAY.** Do not permit people to be in the immediate work area, especially when the electrical tool is operating.
- DO NOT FORCE THE TOOL** to perform an operation for which it was not designed. It will do a safer and higher quality job by only performing operations for which the tool was intended.

GENERAL SAFETY

- 9. WEAR PROPER CLOTHING.**
Do not wear loose clothing, gloves, neckties, or jewellery. These items can get caught in the machine during operations and pull the operator into the moving parts. The user must wear a protective cover on their hair, if hair is long, to prevent it from contacting any moving parts.
- 10. CHILDPROOF THE WORKSHOP AREA** by removing switch keys, unplugging tools from the electrical receptacles, and using padlocks.
- 11. ALWAYS UNPLUG THE TOOL FROM THE ELECTRICAL RECEPTACLE** when making adjustments, changing parts or performing any maintenance.
- 12. KEEP PROTECTIVE GUARDS IN PLACE AND IN WORKING ORDER.**
- 13. AVOID ACCIDENTAL STARTING.** Make sure that the power switch is in the "OFF" position before plugging in the power cord to the electrical receptacle.
- 14. REMOVE ALL MAINTENANCE TOOLS** from the immediate area prior to turning "ON" the machine.
- 15. USE ONLY RECOMMENDED ACCESSORIES.** Use of incorrect or improper accessories could cause serious injury to the operator and cause damage to the tool. If in doubt, check the instruction manual that comes with that particular accessory.
- 16. NEVER LEAVE A RUNNING TOOL UNATTENDED.** Turn the power switch to the "OFF" position. **DO NOT** leave the tool until it has come to a complete stop.
- 17. DO NOT STAND ON A TOOL.** Serious injury could result if the tool tips over, or you accidentally contact the tool.
- 18. DO NOT STORE ANYTHING ABOVE OR NEAR** the tool where anyone might try to stand on the tool to reach it.
- 19. MAINTAIN YOUR BALANCE.** Do not extend yourself over the tool. Wear oil resistant rubber soled shoes. Keep floor clear of debris, grease, and wax.
- 20. MAINTAIN TOOLS WITH CARE.** Always keep tools clean and in good working order. Keep all blades and tool bits sharp, dress grinding wheels and change other abrasive accessories when worn.
- 21. EACH AND EVERY TIME, CHECK FOR DAMAGED PARTS PRIOR TO USING THE TOOL.** Carefully check all guards to see that they operate properly, are not damaged, and perform their intended functions. Check for alignment, binding or breaking of moving parts. A guard or other part that is damaged should be immediately repaired or replaced.
- 22. DO NOT OPERATE TOOL WHILE TIRED, OR UNDER THE INFLUENCE OF DRUGS, MEDICATION OR ALCOHOL.**

- 23. SECURE ALL WORK.** Use clamps or jigs to secure the work piece. This is safer than attempting to hold the work piece with your hands.
- 24. STAY ALERT, WATCH WHAT YOU ARE DOING, AND USE COMMON SENSE WHEN OPERATING A POWER TOOL.** A moment of inattention while operating power tools may result in serious personal injury.
- 25. ALWAYS WEAR A DUST MASK TO PREVENT INHALING DANGEROUS DUST OR AIRBORNE PARTICLES,** including wood dust, crystalline silica dust and asbestos dust. Direct particles away from face and body. Always operate tool in well ventilated area and provide for proper dust removal. Use dust collection system wherever possible. Exposure to dust may cause serious and permanent respiratory or other injury, including silicosis (a serious lung disease), cancer, and death. Avoid breathing dust, and avoid prolonged contact with dust. Allowing dust to get into your mouth or eyes, or lay on your skin may promote absorption of harmful material. Always use properly fitting AS/NZS approved respiratory protection appropriate for the dust exposure, and wash exposed areas with soap and water.
- 26. USE A PROPER EXTENSION CORD IN GOOD CONDITION.** Use of extension cords should be avoided where possible. When using an extension cord, be sure to have a cord heavy enough to carry the current your product will draw, and with compatible pin configuration and connections (NEVER use an extension cord rated at less than your machine). Longer run extensions will need heavier duty extension cords. Only connect your extension cord or machine to a receptacle that accepts your plug and never modify your plug to suit a receptacle.

DRUM SANDER SAFETY

1. During normal operations, there is a tendency for the tool to tip over, slide, or walk on the supporting surface. **ALWAYS SECURE TOOL TO WORKBENCH OR WORKSTAND.**
2. **NEVER** perform the sanding operation with the sanding drum **DUST COVER OR DRIVE GUARD REMOVED.**
3. **NEVER** make a sanding pass **DEEPER THAN** 0.8 mm ($\frac{1}{32}$ ").
4. **DO NOT** sand material **SHORTER THAN** 76 mm (3") or narrower than 19 mm ($\frac{3}{4}$ ").
5. **MAINTAIN THE PROPER RELATIONSHIP** between the infeed and outfeed surfaces and the sander drum path.
6. **SUPPORT THE WORKPIECE ADEQUATELY** at all times during operation; maintain control of the work at all times.
7. **DO NOT BACK THE WORK** toward the infeed table.
8. Do not attempt to perform an abnormal or little used operation without the use of **STURDY AND ADEQUATE JIGS, FIXTURES, STOPS** and a thorough understanding of the operation being performed.
9. Before starting, **RECHECK** to make certain adjustments are correct and all locks and screws are tight.
10. Always **STOP THE MOTOR** and disconnect the power source **BEFORE MAKING ANY ADJUSTMENTS** or changing abrasive strips.
11. Stop the machine and **RECHECK** the motor/drum mounting bolts and feed rollers for tightness **AFTER ABOUT 50 HOURS** of operation.
12. **DO NOT FORCE-FEED** the work piece through the machine. Let the sander apply the proper feed rate.
13. **CHECK THE FEED BELT** occasionally to be sure there is no debris or sawdust between any components.
14. **SAND ONLY SOUND LUMBER;** there should be no loose knots and as few tight knots as possible. Make sure the work piece is free from nails, screws, stones, or other foreign objects that could damage the sanding drum or feed belt.
15. Never stand directly in line with either the infeed or outfeed sides. **STAND TO ONE SIDE.**
16. **MAKE SURE THE ABRASIVE STRIP IS ATTACHED** as described in the operation instructions. An improperly attached abrasive strip could come loose during operation and damage the work piece or internal components.
17. **NEVER PUT YOUR FINGERS INTO THE DUST PORT** or under the drum dust cover.
18. Allow the sanding drum to **REACH FULL SPEED** before using the Wide Drum Sander.

ELECTRICAL SAFETY

WARNING

This tool must be grounded while in use to protect the operator from electric shock. IN THE EVENT OF A MALFUNCTION OR BREAKDOWN, grounding provides the path of least resistance for electric current and reduces the risk of electric shock. This tool may be equipped with an electric cord that has an equipment grounding conductor and a grounding plug. **The plug MUST be plugged** into a matching electrical receptacle that is properly installed and grounded in accordance with **ALL** local codes and ordinances.

DO NOT MODIFY THE PLUG PROVIDED.

If it will not fit the electrical receptacle, have the proper electrical receptacle installed by a qualified electrician.

IMPROPER ELECTRICAL CONNECTION of the equipment grounding conductor can result in risk of electric shock. The conductor with the green insulation (with or without yellow stripes) is the equipment grounding conductor. **DO NOT** connect the equipment grounding conductor to a live terminal if repair or replacement of the electric cord or plug is necessary.

CHECK WITH A QUALIFIED ELECTRICIAN or service personnel if you do not completely understand the grounding instructions, or if you are not sure the tool is properly grounded.

Use only a 3-wire extension cord that has a 3-prong grounding plug and a 3-pole receptacle that accepts the tool's plug. Replace a damaged or worn cord immediately.

Power tools and machinery are intended for use on a circuit that has an electrical receptacle as shown in **FIGURE A** that shows a 10 Amp 3-wire electrical plug and corresponding electrical receptacle that has a grounding conductor.

If this particular tool has been designed and fitted with a two prong electrical plug, ensure it displays the 'Double Insulated' logo shown in **FIGURE B**, before connecting to a 3-wire receptacle.

WARNING

Never modify the standard fitted electrical plugs to fit your receptacle.



OVERVIEW

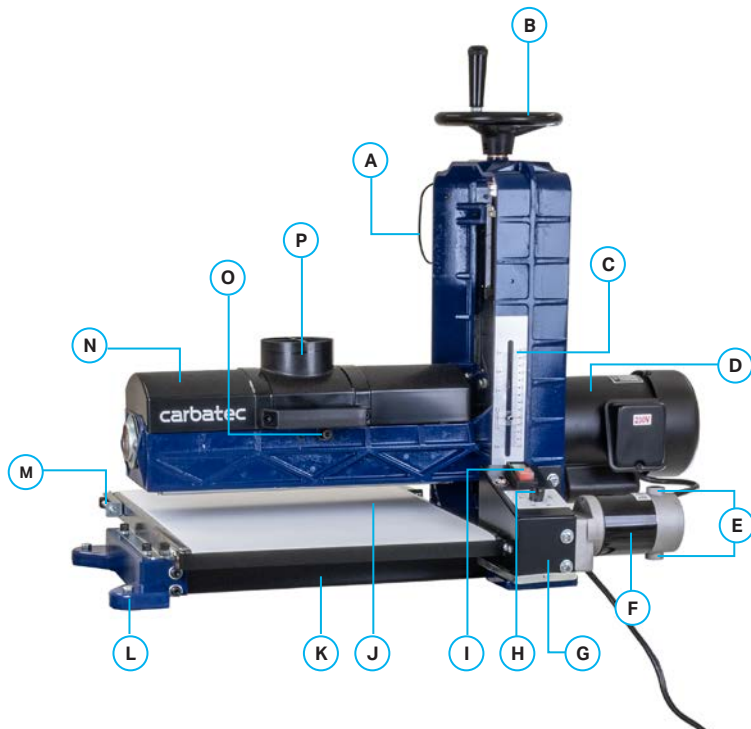

- A. Dust hose hook
- B. Height adjustment handle
- C. Height scale
- D. Sanding drum drive motor
- E. Conveyor feed motor brush caps
- F. Conveyor feed motor
- G. Variable speed control box
- H. Conveyor belt speed control knob
- I. Power switch
- J. Conveyor belt
- K. Front nip guard feed belt
- L. Feet (x4)
- M. Conveyor belt tracking adjuster
- N. Sanding drum dust cover
- O. Dust cover latch
- P. Dust collection port (4")
- Q. Elevation tension adjustment screws
- R. Conveyor belt tracking adjuster

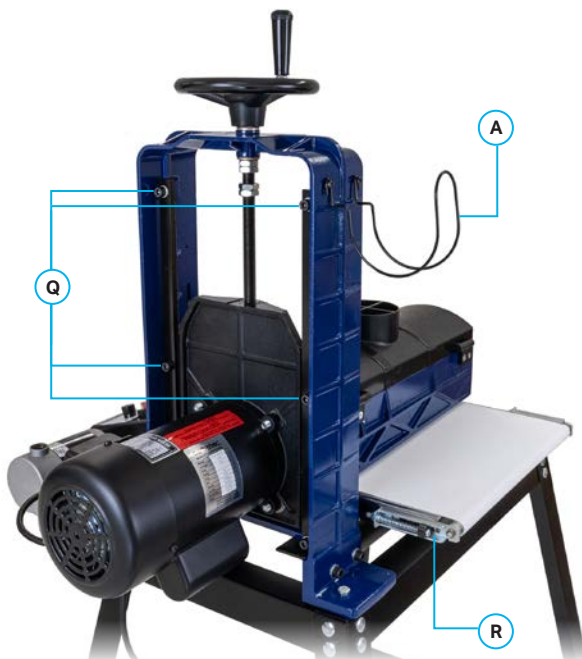

The stand is sold separately.

SPECIFICATIONS

MACHINE	WDS-4080P
WARRANTY	2 years
POWER	230 V / 50 Hz regular 10 A plug
FEED BELT MOTOR	50 W (1-15 HP)
FEED BELT SPEED	Variable 0.6 - 3 m / min
SANDING DRUM MOTOR	750 W (1 HP) AC induction
SANDING DRUM SPEED	1420 RPM
SANDING DRUM DIAMETER	127 mm
MINIMUM MATERIAL THICKNESS	3 mm
MAXIMUM MATERIAL THICKNESS	127 mm
MAXIMUM MATERIAL WIDTH	400 mm single pass 800 mm double pass
DUST PORT	1 × 100 mm (4")
WORKSHOP FOOTPRINT (W×D×H)	870 × 590 × 720 mm (unit only - no stand)
SHIPPING WEIGHT	70 kg
NETT WEIGHT	50 kg

**WARNING**

Any uses beyond its designed purpose may be dangerous.
Always wear applicable AS/NZS approved PPE.

INTRODUCTION TO DRUM SANDING

A. FUNCTION

Drum sanding, sometimes referred to as "abrasive planing" is a repetitive process of sanding both sides of wooden stock to a desired thickness and/or smoothness. When this process is performed correctly, both face surfaces will be parallel to one another.

DO NOT CONFUSE DRUM SANDING WITH THICKNESS PLANING!

Drum sanding gradually removes material in increments of 0.8 mm ($\frac{1}{32}$ ") or less depending on sanding grit, stock hardness, stock width, etc. Thickness planing, on the other hand, is for quick, bulk material removal at rates up to 3 mm ($\frac{1}{8}$ ") per pass with portable machines. If you have used a thickness planer to smooth and dimension stock, you will quickly learn to work with your new drum sander and not against the machine. Be patient, let the drum sander do the work, 0.8 mm ($\frac{1}{32}$ ") or less per pass for best results.

The most common mistake made with a drum sander is forcing it to remove too much material too fast. Variables such as sandpaper grit, stock width, wood type, feed rate, and moisture content all influence how much material can be removed in a single pass.

B. DRUM SANDING ADVANTAGES

One advantage of this wide drum sander is that you can work with material up to 800 mm (32") wide because of its open side design. Although you still abrasive sand with the grain, you do not have to read the grain to prevent tear-out. This is especially important with thin stock and material with convoluted or mixed grain directions, like burl, crotch, and tiger patterns.

Drum sanders exert much less pressure on stock than a thickness planer, giving you the capability of working with very thin material. You have the ability to sand to veneer thickness if desired, expanding your woodworking horizons. You can also sand smaller length wood, odd-shaped pieces, and end grain.

C. REMOVING LUMBER CUP

The ideal machine for removing cup from lumber is a jointer. However, because of the minimal pressure exerted by the drum sander, it is possible to remove cup, since the lumber is not compressed flat on feed belt and table. Be patient, this process can take quite a while depending on cup depth. Feed the stock into the machine cup crown up (edges resting on feed belt) and use a coarse grit abrasive. Repeat until the crown is flat. With one face now flat, flip the board over and sand it flat. Do not be shocked by how thin the board may become after all cup has been removed.

Board warp and twist will not be remedied by a drum sander, or a planer, for that matter. Always inspect your lumber for warp and twist before drum sanding since it is prone to hanging-up in the machine, shorter length lumber in this condition is especially troublesome.

D. PLAN YOUR WORK IN ADVANCE

Planning your drum sanding operations in advance will minimize setups, work time, and frustration level. Group material to be sanded by thickness and grit requirements and work through each required sanding grit starting with the thickest material through the thinnest, then change over to the next finer grit and begin the process again.

We suggest that you experiment with the various sanding grits and wood species to determine the results you can expect before ruining project material. With new set-ups, always test with scrap lumber before sanding your project material.

E. WOOD SPECIES TO BE CAUTIOUS WITH

Highly resinous species will tend to quickly clog (load-up) abrasives and in many cases abrasive loading cannot be removed with belt cleaning sticks. The most notorious abrasive loaders are some common pine species. It is nearly impossible to clear the abrasive of the pitch, sap, sawdust combination.

Be aware of species that have toxic properties, such as members of the rosewood family (i.e. cocobolo). Despite dust control, you may inhale small airborne particles or suffer allergic reactions through handling of stock.

Wear applicable AS/ANZ approved PPE.

ASSEMBLY

To keep freight costs to a minimum and reduce damage in transport, this wide drum sander will require some assembly.

- The drum sander is not pre-assembled. After unpacking, the machine must be installed prior to use.
- Transport the drum sander in its packing crate to a place near its final installation site before unpacking it.
- If the packaging shows signs of possible transport damage, take the necessary precautions not to damage the machine when unpacking.
- If any damage is discovered, the carrier and/or shipper must be notified of this fact immediately to establish any claim which might arise.

F. PLACEMENT LOCATION

Consider anticipated workpiece sizes and additional space needed for auxiliary stands, work tables, or other machinery when establishing a location for this machine in the shop. See dimensions on page 13, for reference.

16

G. ASSEMBLING THE HEIGHT ADJUSTMENT HANDLE AND THE DUST HOSE HOOK

1. Screw the height adjustment handle into the threaded nut in the height adjustment crank using a slotted screwdriver until snug. **Fig. G1**
2. Locate the 4 mm set screw threaded into the side of the height adjustment crank. Position the height adjustment crank over the height adjustment shaft with the set screw aligned with the machined flat area on the height adjustment shaft. **Fig. G2**
3. Lower the height adjustment handle assembly onto the height adjustment shaft and tighten the set screw with the supplied 4mm hex wrench key. **Fig. G3**

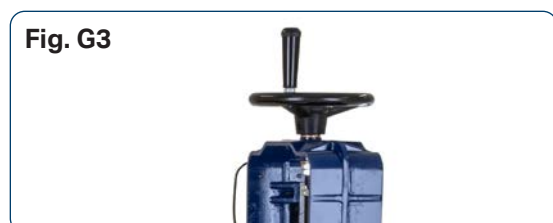
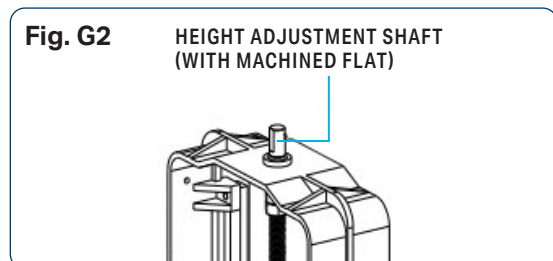
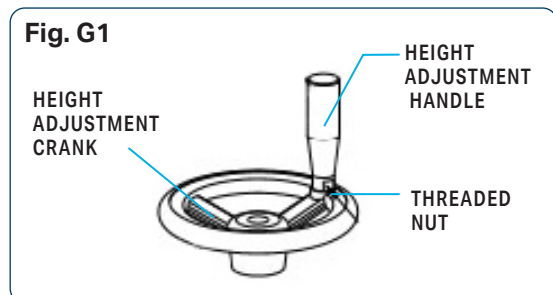

4. Assemble the dust hose hook with the two supplied screws.
Fig. G4 & G5

IMPORTANT: Secure the assembled wide drum sander to an accessory work stand or to an adequately stable workbench or stand before operating the machine.

H. INSTALLING NEW ABRASIVE STRIPS

Abrasive strips are available in precut strips which require no special measuring or trimming before installation. The abrasive strips are tapered at the ends to be wrapped radially around the drum to provide a continuous sanding surface. You may cut your own strips from stock using the cutting diagram.

Fig. H1

Alternatively, you can use the included abrasive strips as a pattern for cutting your new replacement strips.

1. Ensure that the power switch is off and disconnect the power cord from the outlet.
2. Begin the abrasive strip installation by inserting the tip of the tapered strip into the slot in the left side of the drum while depressing the clip. Approximately one inch of material should be inserted into the slot to make the connection in the abrasive clip. Release clip pressure once the inserted tapered end is securely loaded in the clip jaws.

Fig. H2

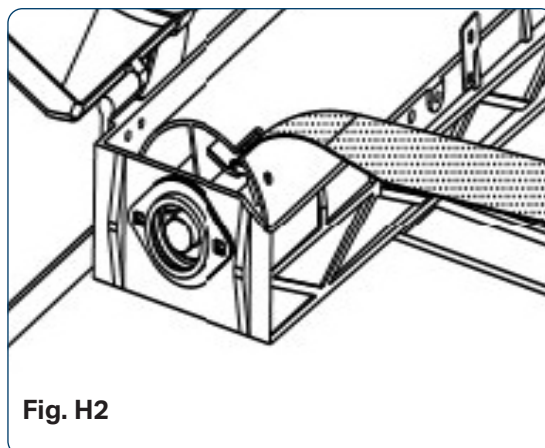
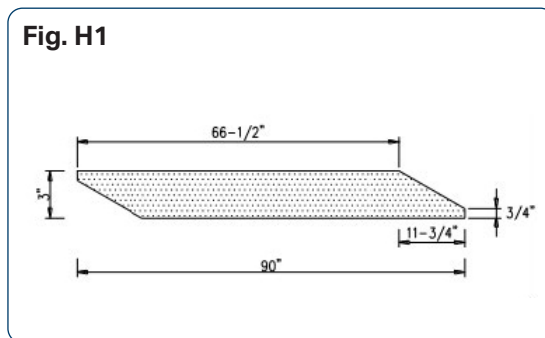

ASSEMBLY

3. Once the abrasive strip is secured in the left clip, stand in front of the unit and radially wrap the abrasive material. Roll the drum away from you with your left hand while holding tension on the abrasive strip with your right hand and guiding the material onto the drum. Use this technique to wrap the abrasive strip edge to edge radially around the drum. Make sure you do not overlap the material as you wrap the abrasive. The material should be flush to slightly gapped, but not overlapped.

Fig. H3

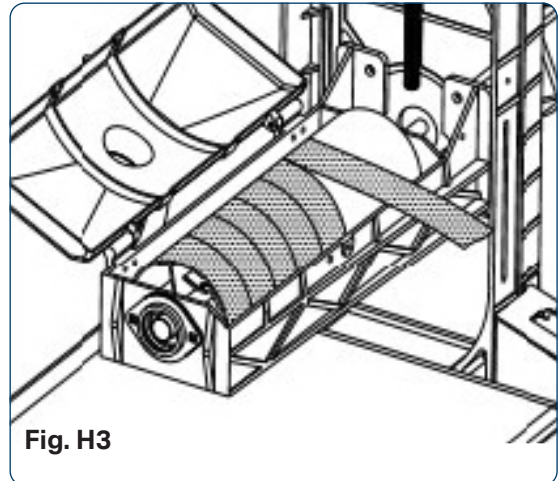

4. When you have completely wrapped the drum, keep tension on the strip and insert the remaining tapered end of the strip into the slot in the drum. Using your right hand, raise the tensioner clip completely to open the jaws. Insert the tapered end of the abrasive strip, and release the tensioner clip to secure the abrasive strip. The tensioner clip will secure and tension the abrasive strip during use and will hold tension in the event the strip stretches during use. If the abrasive strip is not tightly captured, the tensioner clip was not raised sufficiently to open the jaws properly before inserting the abrasive strip.

Fig. H4

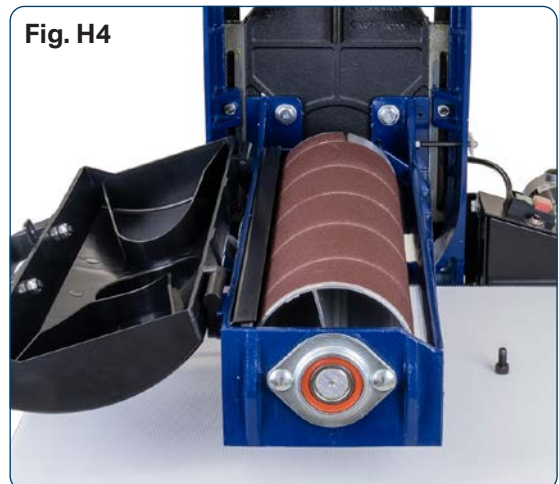

NOTE: In some cases, if the abrasive strip stretched, it may be necessary to re-adjust or reposition the abrasive clip points on the abrasive strip. Ensure the tension remains positive on the abrasive strip during extended use.

MACHINE ADJUSTMENTS

NOTE: Your wide drum sander was aligned during assembly. However, due to stresses imposed on the unit during shipment, you may need to adjust or align your unit to return it to perfect alignment. It is very important that the following adjustments be performed as described.

I. SANDING DRUM DEFLECTION

Before beginning the sanding drum alignment procedures outlined in the following section, ensure that minimal upward deflection of the sanding drum occurs when sanding.

The three primary causes of excessive sanding deflection are:

- **Excessive depth of cut.**
Decrease the depth of cut to minimize pressure on the sanding drum assembly.
- **Loose elevation tension screws.**
Refer to step one in the drum alignment section for correct adjustment procedure.
- **Loose motor/sanding drum assembly mounting bolts.**
Check the tightness of the four (4) bolts, 2 upper and 2 lower, and tighten as needed.

Fig. I

MOTOR/SANDING DRUM ASSEMBLY
MOUNTING BOLTS
(2 lower bolts hidden from view)

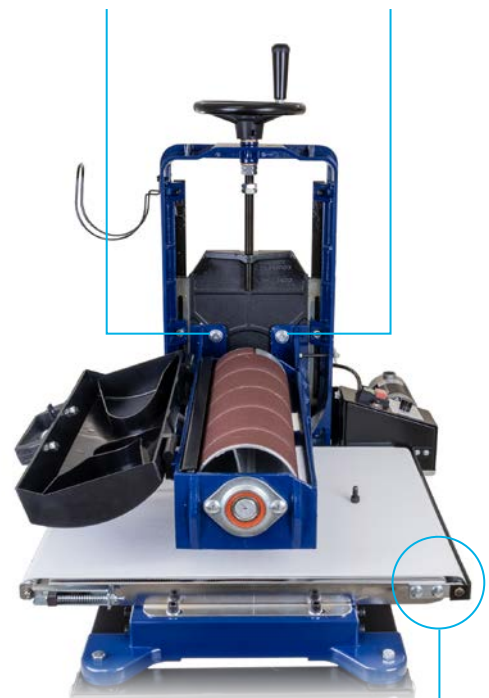

FRONT
NIP GUARD

J. DRUM ALIGNMENT

Check the tightness of the elevation tension adjustment screws. The tightness of these screws must be adjusted to allow smooth height adjustments, while ensuring a tight enough fit to limit drum deflection. If the screws are too loose, the drum will deflect during use, causing an uneven sanding surface. If the screws are too tight, sanding drum height adjustment will be difficult.

To adjust the elevation tension adjustment screws:

1. Loosen the lock nuts, securing each screw in place.
2. Loosen or tighten each screw, as required, in ¼ turn increments to attain the desired fit and smoothness.
3. Re-tighten the lock nuts to secure the tension screws in position.

K. TABLE ALIGNMENT

Check the sanding drum to conveyor table alignment by first removing the abrasive strip from the drum. The purpose of this adjustment is to achieve equal distances at point A and point B which will ensure that the drum is parallel to the feed table and provide uniform sanding.

Fig. K1

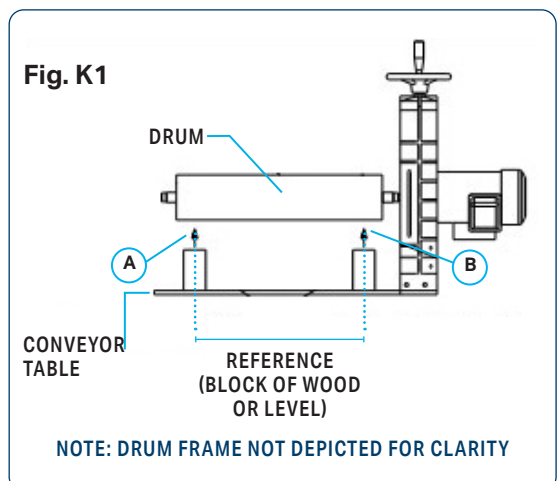
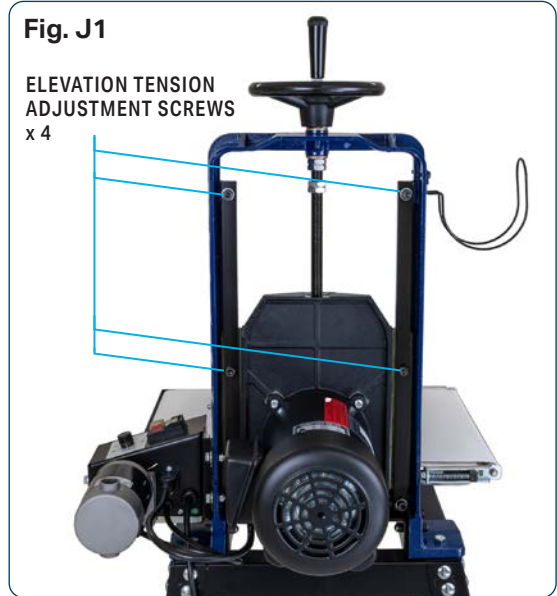

If the measurement at A, as shown in figure K1, is greater than the same point at B by 0.5 mm (0.02") or less, proceed as follows:

1. Loosen the 2 outboard conveyor table mounting bolts.
Fig. K2 & K3
2. Slide one or both of the supplied shims as needed under the edge of the conveyor table.
3. Tighten conveyor table mounting bolts. Recheck the measurement at A and at B.
4. Test sand a piece of timber and check for uniform thickness.

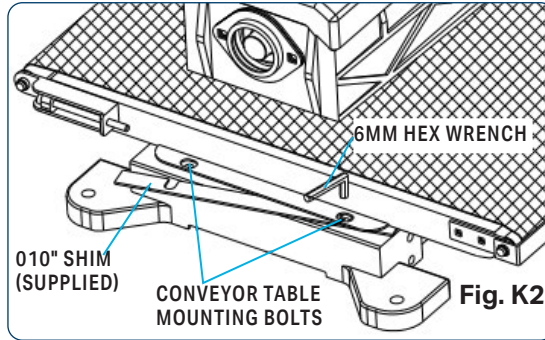

If the measurement at A exceeds B by more than 0.5 mm (0.02"), or if distance B is greater than A, proceed as follows:

1. Loosen the two front and two rear adjustment bolts, thus allowing the entire drum assembly to pivot.
Fig. K4, K5 & K6

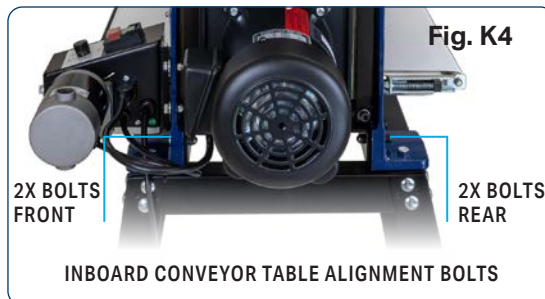

Note: if the unit is bolted to a stand or bench, loosen the mounting bolts at the motor end.

2. Using the height adjustment handle assembly, lower the drum until the distances at A and B are equal. Tighten the alignment bolts and the mounting bolts.
3. Test sand a piece of wood and check for uniform thickness. Repeat the above procedure if necessary.

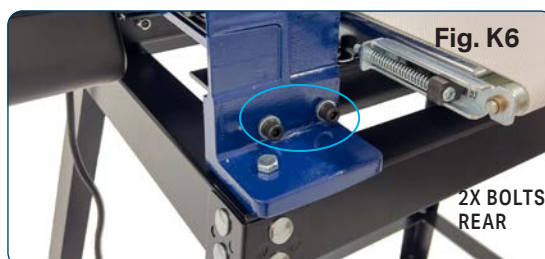

MACHINE ADJUSTMENTS

L. ADJUSTING THE CONVEYOR BELT TRACKING AND TENSION

Occasional adjustment of the conveyor feed belt tracking may be required due to belt stretching, normal wear and tear, and improper tensioning. Ideally, the conveyor feed belt should track in the center area of the conveyor feed belt table.

Conveyor feed belt tracking adjustment screws are located on both the inboard and outboard sides on the rear of the wide drum sander.

Fig. L1 & Fig. L2

1. To tighten the tracking tension, the tracking screw is rotated clockwise while holding its nut in place with a $\frac{7}{16}$ open end wrench (not supplied).
2. To loosen the tracking tension, the tracking screw is rotated counterclockwise while the nut is held with the wrench.
3. If the conveyor feed belt is tracking towards the inboard (motor side) of the machine, tighten (add tension) to the tracking adjustment screw on that side of the machine.

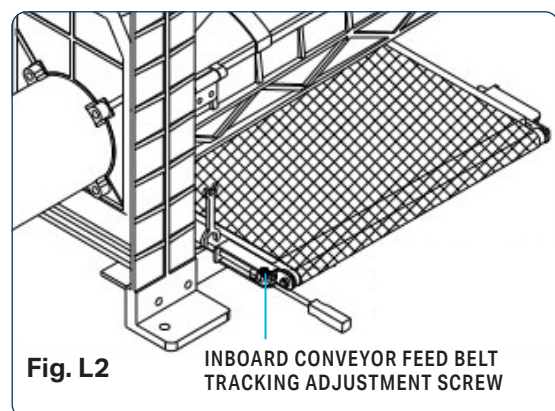
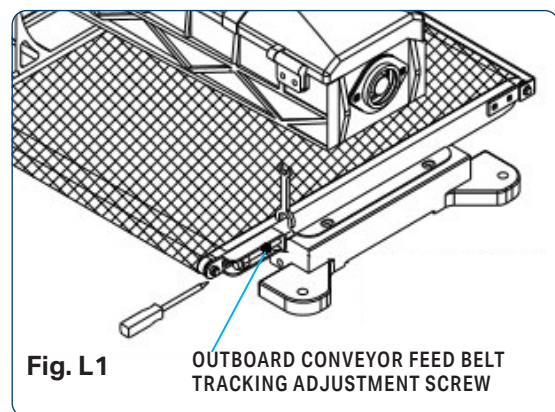

NOTE: Due to the width of the conveyor feed belt, tracking adjustment may not become apparent immediately! Increase the speed of the conveyor feed belt to quicken the effects of your adjustments. Make small measured corrections of approximately $\frac{1}{4}$ turn increments and evaluate the results. Readjust as necessary until the proper tracking solution is found.

M. REPLACING THE CONVEYOR BELT

Common causes which require replacement of the conveyor feed belt are:

- normal wear and tear,
- inadvertent contact with the sanding drum abrasive during operation,
- tears caused by mis-tracking of the conveyor feed belt,
- excessive build-up of non-removable film.

The following steps describe how to remove and replace the conveyor feed belt when necessary:

1. Using the height adjustment handle, raise the sanding drum to its highest position (roughly 3" above the conveyor belt table)
2. Using a phillips type screwdriver, remove the 2 screws and star washer securing the front nip guard to the variable speed control box. Then remove the front nip guard by sliding it to the left and off the outboard drive roller bushing.
3. Using the supplied 6 mm hex wrench key, remove both conveyor table mounting bolts on the outboard, open side of the wide drum sander.

Fig. M2

Fig. M1

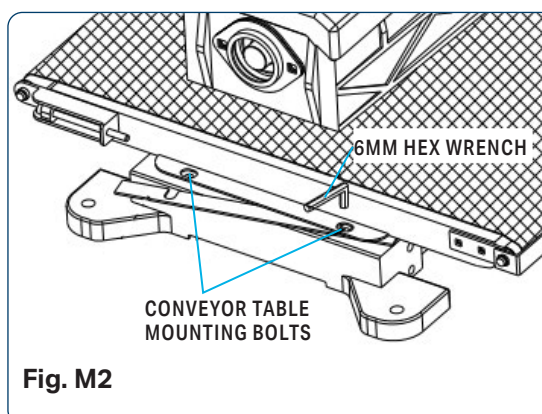
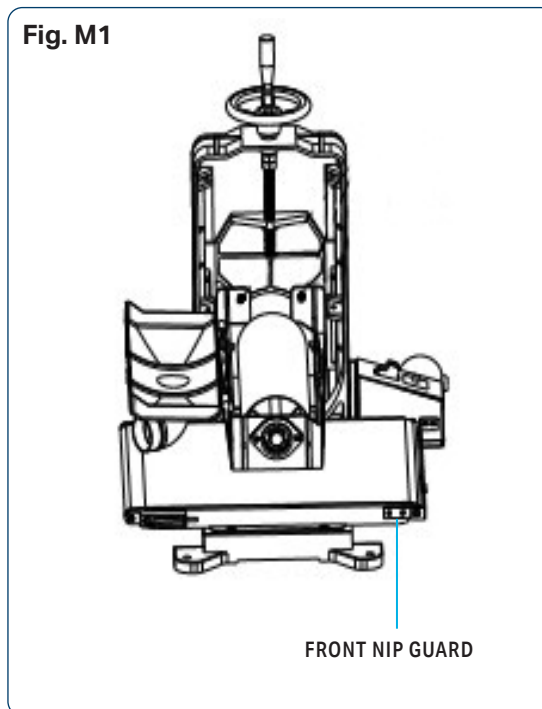

Fig. M2

MACHINE ADJUSTMENTS

4. Reduce tension on the conveyor feed belt by rotating both the inboard and outboard conveyor feed belt tracking adjustment screws in a counter clockwise direction.

Fig. M3 & M4

5. Remove the used conveyor feed belt by grasping both sides of the belt. Gently lift the conveyor table as you slide off the conveyor feed belt. If the belt will not move, further reduce the tension on the feed belt and ensure you are lifting the table high enough to allow the feed belt to slide off.

Fig. M5

6. To install the replacement conveyor feed belt, follow step 5 through 2 in reverse order. Center the new feed belt on the conveyor feed belt table and evenly tension the new feed belt using the inboard and outboard tracking adjusters. If you experience tracking problems, consult the conveyor feed belt tracking adjustment section.

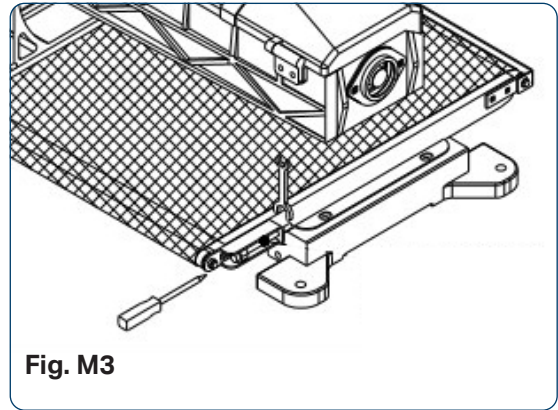

Fig. M3

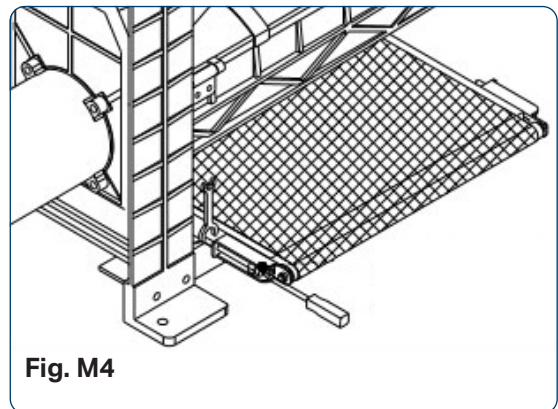

Fig. M4

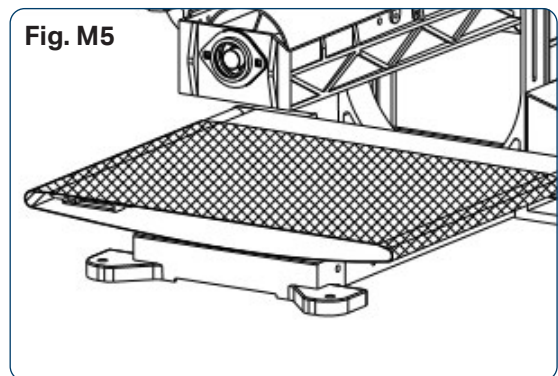

Fig. M5

OPERATION

N. OPERATION

1. With power off, rest stock on the feed table and advance the stock to a point so that you can adjust height of sanding drum to equal thickness of stock at its greatest point.
2. Remove stock.
3. Connect and turn on dust collection equipment.
4. Adjust feed rate to match sanding requirements and width of stock.
5. Turn on unit and rest stock on the feed conveyor table allowing the feed belt to carry the stock into and engage the sanding action of the drum. Support long stock as necessary during the feed operation. Once the sanding operation feed allows, reposition yourself to the out-feed side of the machine to accept, support, and control the board as it exits the wide drum sander.

Note: Do not apply upward or downward pressure when supporting and guiding stock through the sander. To do so may induce snipe (sander drum dig-in) into the sanded stock.

6. Reverse the feed direction of the stock on successive passes, while adjusting the depth of cut using the height adjustment handle assembly.

Several variables affect the proper depth of cut selected:

- abrasive grit choice
- width of stock
- hardness of stock
- feed rate
- moisture content of stock



WARNING

Dust exposure created while using machinery may cause cancer, birth defects, or long-term respiratory damage. Always wear goggles and a AS/NZS 1716:2012 compliant approved respirator when working with dust.

MAINTENANCE

O. DRUM ABRASIVE STRIP CLEANING

During use, the sanding strip abrasive may become clogged with sawdust, causing insufficient sanding, marring of workpiece, or burning of the workpiece. With the machine off and unplugged from its power source, occasionally check the condition of the abrasive strip on the sanding drum for clogging. This should be done often, especially with resinous woods, because material can become so packed into the abrasive that it cannot be removed, and the abrasive strip must be replaced.

1. Heed all warnings and use extreme caution when performing this cleaning operation.
2. Set the conveyor belt speed control knob to lowest feed setting. Avoid contact with conveyor feed belt.
3. Open the protective dust cover to expose the sanding drum and abrasive strip.
4. Use a long belt cleaning stick to distance your hands from the rotating drum
5. Turn on the machine, grip the belt cleaning stick with two hands, rest the cleaning stick on the casting which houses the sanding drum. Gently lower the cleaning stick onto the rotating drum, moving the cleaning stick from side to side to remove the impacted sawdust.
6. When cleaning is completed, remove the stick, turn off the machine, and close and latch the protective dust cover.

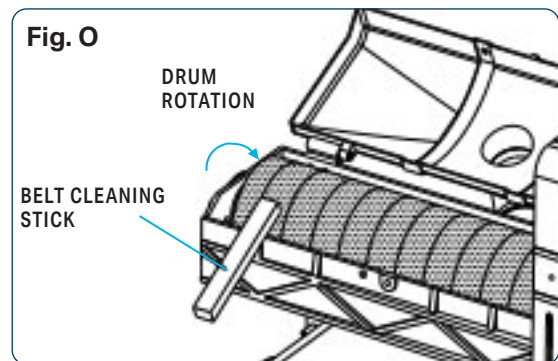

TROUBLESHOOTING

TO PREVENT INJURY TO YOURSELF or damage to the wide drum sander, turn the switch to the "OFF" position and unplug the power cord from the electrical receptacle before making any adjustments.

PROBLEM	LIKELY CAUSE(S)	SOLUTION(S)
The machine does not work when switched on.	<ol style="list-style-type: none"> No power supply. Defective switch. 	<ol style="list-style-type: none"> Check all plug connections. Check the cable for breakage. Check the fuse, or reset circuit breaker. Return machine to your local dealer for repair.
Sanding drum does not come up to speed.	<ol style="list-style-type: none"> Extension cord too light or too long. Low current. 	<ol style="list-style-type: none"> Replace with adequate size and length cord. Contact a qualified electrician.
Machine vibrates excessively.	<ol style="list-style-type: none"> Stand or base on uneven surface. Bearings worn. 	<ol style="list-style-type: none"> Adjust stand or base so that it rests evenly on the floor. Replace bearings.
Sanded edge not square.	<ol style="list-style-type: none"> Table not square to sanding drum. 	<ol style="list-style-type: none"> Follow table alignment procedure (page 20).
Sanding marks on timber.	<ol style="list-style-type: none"> Wrong grit sanding sleeve. Feed pressure too great. 	<ol style="list-style-type: none"> Use coarser grit for stock removal and fine grit for finish sanding. Do not force workpiece against drum.

WIRING DIAGRAM

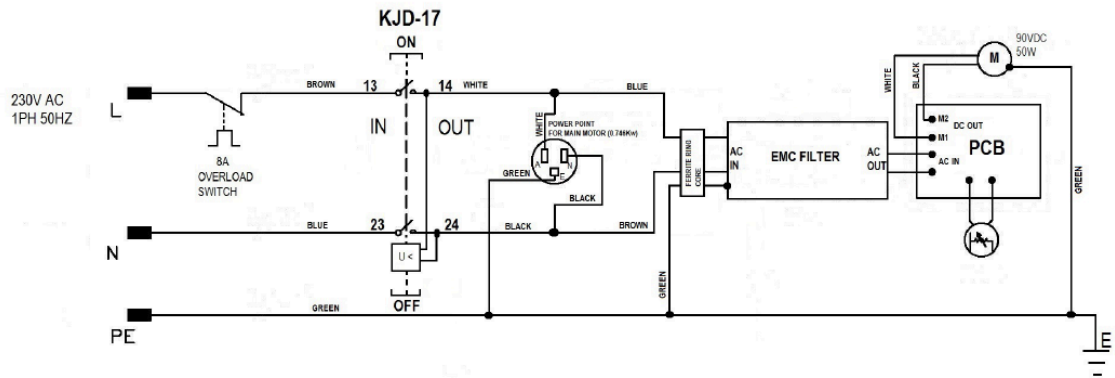

PARTS DIAGRAM

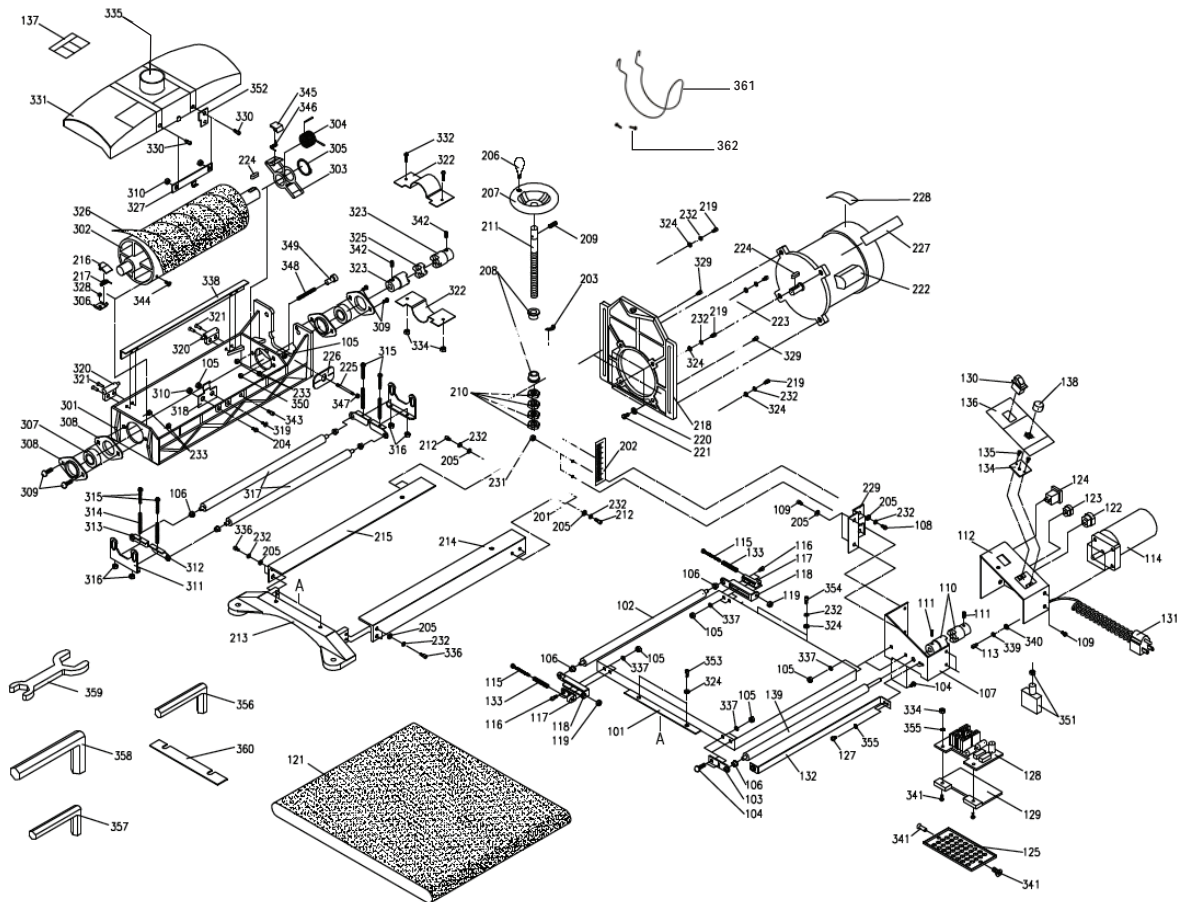

400 mm / 800 mm Wide Drum Sander
WDS-4080P

PARTS LIST

PART REF	DESCRIPTION	PART REF.	DESCRIPTION	PART REF.	DESCRIPTION
101	FEED TABLE	206	HAND KNOB	318	FASTEN PLATE
102	OUT FEED ROLLER	207	HEIGHT CONTROL WHEEL	319	SCREW
103	FIXING PLATE	208	CONNECTING BUSH	320	COVER HINGE
104	SCREW	209	SET SCREW	321	INTERNAL NIP GUARD SCREW
105	NUT	210	NUT	322	AUX GUARD
106	FEED ROLLER BUSHING	211	HEIGHT CONTROL SHAFT	323	COMPOUND JOINTER
107	SWITCH BOX HOUSING	213	ARCH STAND	324	SET SCREW
108	NUT	214	FEED ROLLER SUPPORT (L)	325	COMPOUND JOINTER
109	HEX BOLT	215	FEED ROLLER SUPPORT (R)	326	SET SCREW
110	COUPLE AXEL	216	TAPPING CHUCK	327	HOOKING PLATE
111	SET SCREW	217	ADJUSTING SHIM	328	NUT
112	SWITCH BOX COVER	218	MOTOR MOUNTING FRAME	329	SCREW
113	SCREW CAP	219	SLIDING SCREW	330	BOLT
114	REDUCTION MOTOR	220	WASHER	331	DUST COVER
115	FASTEN BOLT	221	SCREW	332	SCREW
116	HEX SCREW	222	MOTOR	334	NUT
117	TENSION ADJ. BLOCK	223	SLIDING RING	335	4" PORT
118	ADJ. SLIDE PLATE	224	KEY	336	FASTENER
119	NUT	225	SCREW	337	LATCHE SCREW
120	SCREW	226	POINTER	338	INTERNAL NIP GUARD
121	FEED BELT	227	WARNING PLATE	339	SPRING WASHER
122	CABLE HOLDER	228	NAME PLATE	340	FLAT WASHER
123	CABLE HOLDER	229	ARCH BRACKET	341	SCREW
124	PLUG SET	230	HEX HD SCREW	342	SET SCREW
125	SWITCH BOX BOTTOM PLATE	231	FLAT WASHER	343	HEX HD SCREW
126	SCREW	232	SPRING WASHER	344	SCREW
127	FRONT NIP GUARD SCREW	233	NUT	345	HOLDER
128	PC BOARD	301	DRUM CASE	346	SPRING
129	INSULATED BOARD	302	DRUM ROLLER	347	NUT
130	SWITCH	303	PULL CLAMP BRACKET	348	SPRING
131	POWER CORD 14AWG	304	SPRING	349	PIN
132	FRONT NIP GUARD	305	STW-28	350	NUT
133	FIXED SPRING	306	FIXED CLAMP BRACKET	351	SWITCH
134	RESISTANCE BOARD	307	BEARING 6205ZZ	352	CLIP
135	SCREW	308	BEARING CAP	353	HEX HD SCREW
136	INDICATOR	309	SCREW	354	HEX HD SCREW
137	STICKER	310	NUT	355	TOOTH LOCK WASHER
138	BOTTOM	311	FIX BRACKET	356	HEX WRENCH 4MM
139	FEED ROLLER	312	FIX BRACKET	357	HEX WRENCH 5MM
201	ARCH	313	FIXING BLOCK	358	HEX WRENCH 6MM
202	DEPTH INDICATOR	314	SPRING	359	OPEN END WRENCH
203	ROTATION INDICATOR	315	SCREW	360	PAD
204	SCREW	316	NUT	361	DUST HOSE HOOK
205	WASHER	317	FASTEN BAR	362	SCREW x2

PARTS LIST

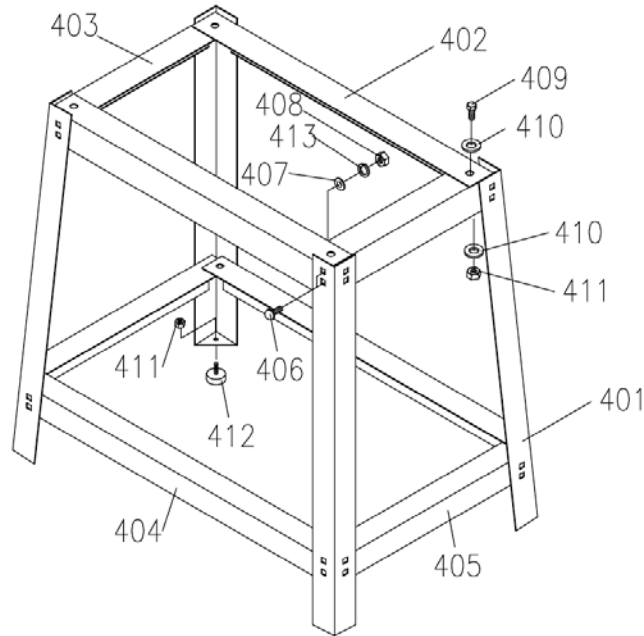

Carbatec Stand to suit WDS-400 and WDS-4080P
Product Code: WDS-400-STAND

THIS STAND IS SOLD SEPARATELY.

PART REF	DESCRIPTION	PART REF.	DESCRIPTION
401	LEG (834MM)	408	M8XP1.25 NUT
402	TOP BRACKET, LONG (655MM)	409	3/8"×16UNC × 1 1/2" HEX HEAD BOLT
403	TOP BRACKET, SHORT (378MM)	410	3/8" WASHER
404	BOTTOM BRACKET, LONG (867MM)	411	3/8"-16UNC NUT
405	BOTTOM BRACKET, LONG (590.5MM)	412	3/8"-16UNC FOOT PAD
406	M8×16 CARRIAGE BOLT	413	5/16" SPRING WASHER
407	5/16" WASHER		

2 YEAR WARRANTY

WARRANTY

- A. We warrant that this Carbatec product will be free from defects caused by faulty workmanship or faulty materials for a period of 2 years from date of sale.
- B. This warranty is in addition to other rights and remedies you may have under a law in relation to the goods.
- C. This warranty does not apply in any of the following cases:
- i. Defects arising from:
 1. fair wear and tear;
 2. corrosive atmosphere;
 3. damage or injury caused by deliberate act, lack of care or failure to comply with the recommended care and maintenance for the goods;
 4. improper use of the goods;
 5. alterations or repairs (not made by us) to the goods;
 - ii. defects arising from an event outside of our control such as fire, flood, earthquake or other natural calamity, motor vehicle or other accident, strike, civil unrest, terrorism or war;
 - iii. to accessory items such as after-market jigs, accessories or other items which are not sold or serviced by us and which are not sold with or were not included with the main unit purchased; or
 - iv. to wearable parts such as drive belts/shafts, bearings, bandsaw tyres, motor brushes, blades or abrasive belts/discs or other cutting or machining implements.
 - v. damage caused to any electrical component, where connected to a power supply outside the country for which it was designed (namely Australia or New Zealand).
- D. If this warranty applies and you have complied with the procedure below for making a claim, we will, at our election, either repair the goods (or those parts of the goods recognised as defective) or will provide a replacement within a reasonable time at our expense.
- E. If this warranty applies, the procedure for making a claim is:
- i. you must contact us by email;
 - ii. you must include in the email the following information:
 1. a copy of the order or receipt for the goods;
 2. the serial or batch number printed on the machinery manufacturing plate; and
 3. a detailed description of the fault and how and when it arose; and
 4. If the fault is a type covered by this warranty, we will then make arrangements with you for the return of the goods to us (for repair or replacement) at our cost using our transport providers or we may decide to attend at your premises to repair or replace the goods.
- F. Our liability (and that of our resellers) under this warranty is wholly limited to repair or replacement of the goods (or those parts of the goods recognised as defective) in accordance with the procedure above and you have no right to other compensation, costs or damages under this warranty. But this does not mean that you may not have other rights under a law in relation to the goods.
- G. If following our inspection of goods returned by you under this warranty it is found that this warranty does not apply and you are not otherwise entitled to repair or replacement by us, you must, if requested by us, reimburse our costs including parts, labour and freight.
- H. This warranty is not transferable and only the person who purchased the goods may make a claim.
- I. Where the goods have been exported outside Australia or New Zealand, the Company may not require the Purchaser to return any allegedly faulty or defective Product for evaluation. However, the Company has the right to request the return for evaluation at purchasers cost.

STATUTORY NOTICE

Our goods come with guarantees that cannot be excluded under the Australian Consumer Law. You are entitled to a replacement or refund for a major failure and for compensation for any other reasonably foreseeable loss or damage. You are also entitled to have the goods repaired or replaced if the goods fail to be of acceptable quality and the failure does not amount to a major failure.



Carbatec Pty Ltd

E info@carbatec.com.au

AU 1800 658 111

NZ 0800 444 329

1/364 New Cleveland Rd,
Tingalpa, QLD
Australia

ABN 84 010 706 242

carbatec.com.au

carbatec®

2 YEAR
WARRANTY